

Differential pH and ORP Sensors

pH/ORP



Hach Digital pH/ORP sensors are available in convertible (PEEK® or Ryton®), insertion, and sanitary body styles. Three electrodes are used in these sensors to increase measurement accuracy and eliminate sensor ground loops.

Features and Benefits

Differential Electrode Measurement Technique

This field-proven technique uses three electrodes instead of the two normally used in conventional pH sensors. Process and reference electrodes measure the pH differentially with respect to a third ground electrode. The end result is unsurpassed measurement accuracy, reduced reference junction potential, and elimination of sensor ground loops. These sensors provide greater reliability, resulting in less downtime and maintenance.

Patented Technology

The former GLI, now a Hach Company brand, invented the Differential Electrode Technique for pH measurement in 1970. The pH^{DM} sensor series (U.S. Patent Number 6395158B1, dated May 28, 2002) takes this field-proven technology to a new level.

Replaceable Salt Bridge/Protector

The unique, replaceable salt bridge holds an extraordinary volume of buffer to extend the working life of the sensor by protecting the reference electrode from harsh process conditions. The salt bridge simply threads onto the end of the sensor if replacement is needed.

Built-in Encapsulated Preamp

Encapsulated construction protects the sensor's built-in preamp from moisture and humidity, ensuring reliable sensor operation. The preamp in the pH^{DM} analog sensor produces a strong signal, enabling the sensor to be located up to 1000 m (3280 ft.) from the analyzer.

Durable Body Materials

Both the digital and analog pH and ORP differential sensors feature a durable PEEK® body for chemical compatibility

with most process solutions. For less aggressive solutions, Hach offers a Ryton® sensor in a convertible style for pH and ORP measurement. A sensor with a stainless steel body is available for immersion applications.

Digital Electronics Modules

Sensors are available with integral digital electronics or with a gateway module for high temperature (above 70°C) applications.

Versatile Mounting Styles

Sensors are available in four mounting styles—convertible, insertion, immersion, and sanitary. Please turn to page 5 for more information.

Full Featured “Plug and Play” sc100 Digital Controller

There's no complicated wiring or set up procedures with the Hach sc100 controller. Just plug in any Hach digital sensor and it's ready to use—it's “plug and play.”

One or two sensors—Use the sc100 Digital Controller to receive data from up to two Hach digital sensors in any combination.

Communications—Multiple alarm/control schemes are available using three relays and two PID control outputs. Communications use analog 4-20 mA and digital MODBUS®/RS485, MODBUS®/RS232 protocols. (Other digital protocols are available. Contact your Hach representative for details.) Every sc100 controller is equipped with wireless communication through an infrared port.

Data logger—A built-in data logger collects measurement data, calibration, verification points, and alarm history for up to 6 months.

DW = drinking water WW = wastewater municipal PW = pure water / power
IW = industrial water E = environmental C = collections FB = food and beverage



Be Right™

DW

WW

PW

IW

Specifications*

pH Sensors

Most pH applications fall in the 2.5 to 12.5 pH range. A Hach pHD sc Differential pH sensor with the wide-range glass process electrode performs exceptionally well in this range. Some industrial applications require accurate measurement and control below 2 or above 12 pH. In these special cases, please contact Hach Technical Support for further details.

Measuring Range

-2 to 14 pH

Sensitivity

± 0.01 pH

Stability

0.03 pH per 24 hours, non-cumulative

Operating Temperature

Digital Sensor: -5 to 70°C (23 to 158°F)

Analog Sensor with Digital Gateway: -5 to 105°C (23 to 221°F)

Immersion Sensor: 0 to 50°C (32 to 122°F)

Flow Rate

3 m (10 ft.) per second, maximum

Sensor Pressure/Temperature Limits

Digital: 6.9 bar at 70°C (100 psi at 158°F)

Analog: 6.9 bar at 105°C (100 psi at 221°F)

Built-in Temperature Element

NTC 300 ohm thermistor for automatic temperature compensation and analyzer temperature readout

Transmission Distance

100 m (328 ft.), maximum

1000 m (3280 ft.), maximum when used with a termination box

Sensor Cable (integral)

4 conductor cable with one shield and polyurethane jacket; rated to 105°C (221°F); 10 m (33 ft.) standard length

Wetted Materials

PEEK® or Ryton® (PVDF), salt bridge of matching material with Kynar® junction, glass process electrode, titanium ground electrode, and Viton® O-ring seals

(pH sensor with optional HF-resistant glass process electrode has 316 stainless steel ground electrode, and perfluoroelastomer wetted O-rings; consult factory for other available wetted O-ring materials)

ORP (Redox) Sensors

For best ORP measuring results in solutions containing zinc, cyanide, cadmium or nickel, Hach recommends using the pHD sc ORP sensor equipped with an optional gold electrode.

Measuring Range

-1500 to +1500 mV

Sensitivity

± 0.5 mV

Stability

2 mV per 24 hours, non-cumulative

Operating Temperature

Digital Sensor: -5 to 70°C (23 to 158°F)

Analog Sensor with Digital Gateway: -5 to 105°C (23 to 221°F)

Immersion Sensor: 0 to 50°C (32 to 122°F)

Flow Rate

3 m (10 ft.) per second, maximum

Sensor Pressure/Temperature Limits

Digital: 6.9 bar at 70°C (100 psi at 158°F)

Analog: 6.9 bar at 105°C (100 psi at 221°F)

Built-in Temperature Element

NTC 300 ohm thermistor for analyzer temperature readout only—no automatic temperature compensation necessary for ORP measurement

Transmission Distance

100 m (328 ft.), maximum

1000 m (3280 ft.), maximum when used with a termination box

Sensor Cable (integral)

4 conductor cable with one shield and polyurethane jacket; rated to 105°C (221°F); 10 m (33 ft.) standard length

Wetted Materials

PEEK® or Ryton® (PVDF), salt bridge of matching material with Kynar® junction, glass and platinum (or plastic and gold) process electrode, titanium ground electrode, and Viton® O-ring seals

*Specifications subject to change without notice.

Engineering Specifications

PEEK® Sensor

1. The pH or ORP sensor shall be of Differential Electrode Technique design using two measuring electrodes to compare the process value to a stable internal reference standard buffer solution. The standard electrode shall have non-flowing and fouling-resistant characteristics.
2. The sensor shall have a hex-shaped body to facilitate mounting, and shall be constructed of PEEK® material for exceptional chemical resistance and mechanical strength. This material shall enable the sensor to be installed in metal fittings without leakage usually caused by heating and cooling cycles when dissimilar materials are threaded together.
3. The sensor shall have a:
 - a) Convertible body style featuring 1-inch NPT threads on both ends to mount into a standard 1-inch pipe tee, into a Hach adapter pipe for union mounting with a standard 1-1/2 inch tee, or onto the end of a pipe for immersion into a vessel.
 - b) Insertion body style featuring 1-inch NPT threads only on the cable end to mount into a Hach ball valve hardware assembly, enabling the sensor to be inserted into or retracted from the process without stopping the process flow.
 - c) Sanitary body style featuring an integral 2-inch flange to mount into a Hach 2-inch sanitary tee. The sanitary body style sensor shall include a special cap and EDPM compound gasket for use with the Hach sanitary hardware.
4. The built-in electronics of the sensor shall be completely encapsulated for protection from moisture and humidity.
5. The sensor shall have a built-in preamplifier to enable the signal to be transmitted up to 100 m (328 ft.) with standard cabling and up to 1000 m (3280 ft.) with a termination box.
6. The sensor signal shall have an integral temperature sensor. The pH sensor shall automatically compensate measured values for changes in process temperature.
7. The ORP sensor shall include a titanium ground electrode (standard) to eliminate ground loop currents in the measuring electrodes.
8. The sensor shall be Hach Company Model pHD sc or pHD for pH or ORP measurement.

Ryton® Sensor

1. The pH or ORP sensor shall be of Differential Electrode Technique design using two measuring electrodes to compare the process value to a stable internal reference standard buffer solution. The standard electrode shall have non-flowing and fouling-resistant characteristics.
2. The sensor shall have a hex-shaped body to facilitate mounting, and shall be constructed of Ryton® material for exceptional chemical resistance and mechanical strength. This material shall enable the sensor to be installed in metal fittings without leakage usually caused by heating and cooling cycles when dissimilar materials are threaded together.
3. The sensor shall have a convertible body style featuring 1-inch NPT threads on both ends to mount into a standard 1-inch pipe tee, into a Hach adapter pipe for union mounting with a standard 1-1/2 inch tee, or onto the end of a pipe for immersion into a vessel.
4. The built-in electronics of the sensor shall be completely encapsulated for protection from moisture and humidity.
5. The sensor shall have a built-in preamplifier to enable the signal to be transmitted up to 100 m (328 ft.) with standard cabling and up to 1000 m (3280 ft.) with a termination box.
6. The sensor signal shall have an integral temperature sensor. The pH sensor shall automatically compensate measured values for changes in process temperature.
7. The ORP sensor shall include a titanium ground electrode (standard) to eliminate ground loop currents in the measuring electrodes.
8. The sensor shall be Hach Company Model pHD sc or pHD for pH or ORP measurement.

Stainless Steel Sensor

1. The pH or ORP sensor shall be of differential electrode technique design using two measuring electrodes to compare the process value to a stable internal reference standard buffer solution. The standard electrode shall have non-flowing and fouling-resistant characteristics.
2. The sensor shall be capable of chain mounting for immersion applications, and shall be constructed of 316 stainless steel.
3. The built-in electronics of the sensor shall be completely encapsulated for protection from moisture and humidity.
4. The sensor shall have a built-in preamplifier to enable the signal to be transmitted up to 100 m (328 ft.) with standard cabling and up to 1000 m (3280 ft.) with a termination box.
5. The sensor signal shall have an integral temperature sensor to automatically compensate measured values for changes in process temperature.
6. The sensor shall include a titanium ground electrode (standard) to eliminate ground loop currents in the measuring electrodes.
7. The sensor shall be Hach Company Model pHD sc or pHD for pH or ORP measurement.

Dimensions

Convertible Style

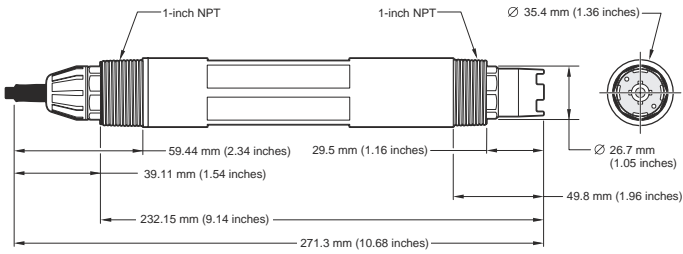

Insertion Style

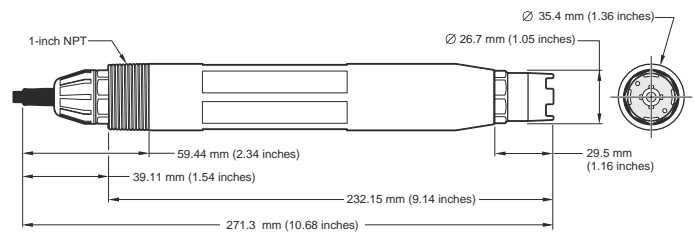

Sanitary Style

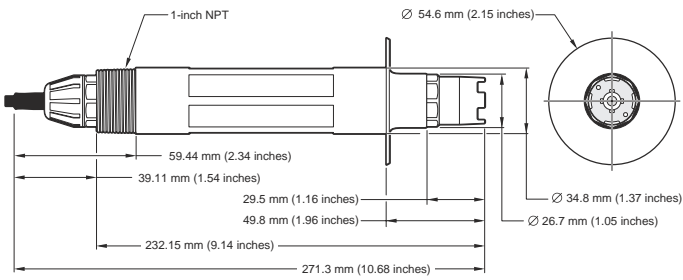

Immersion Style

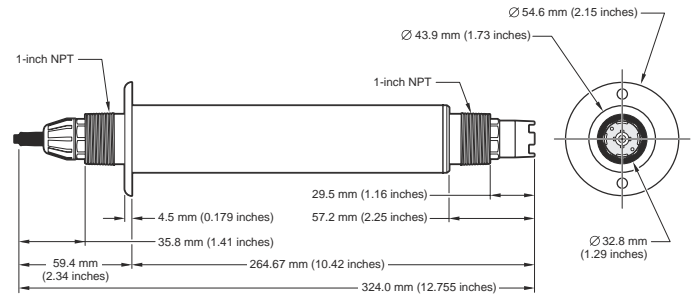

Digital Gateway

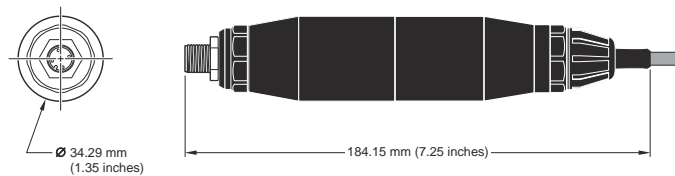

Analog Convertible Style

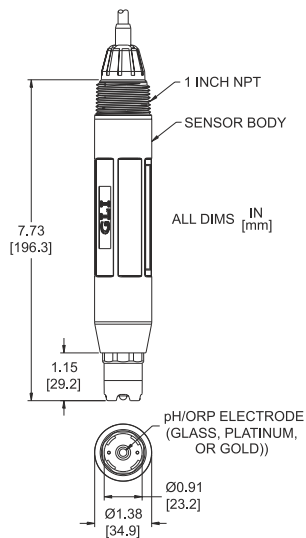

Analog Insertion Style

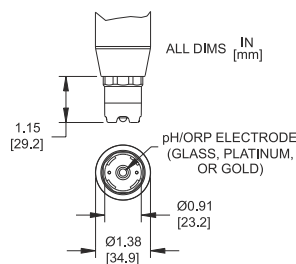

Analog Sanitary Style

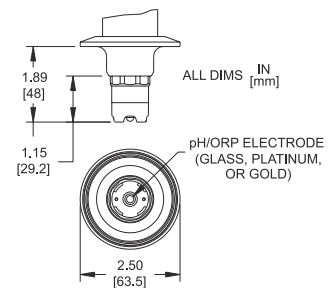

Ordering Information

pHD sc Digital Differential pH/ORP Sensors

All digital sensors include built-in digital electronics and integral 10 m (33 ft.) cable terminated with connector for the sc100 digital controller. Body styles:

- *Convertible* – 1-inch NPT threads at both ends, designed for tee-mounting or other flow through mountings, and pipe mounting for immersion
- *Insertion* – no threads on the electrode end, designed for use with insertion valve assembly
- *Sanitary* – 2-inch flange for a tri-clover style fitting
- *Immersion* – used with chain mounting or pipe mounting

pH Sensors

<u>Product Number</u>	<u>Body Material</u>	<u>Body Style</u>	<u>Electrode Material</u>	<u>Max Temp</u>
DPD1P1	PEEK ¹	Convertible	Glass, General Purpose	70°C (158°F)
DPD1P3	PEEK ¹	Convertible	Glass, HF-resistant	70°C (158°F)
DPD2P1	PEEK ¹	Insertion	Glass, General Purpose	70°C (158°F)
DPD3P1	PEEK ¹	Sanitary	Glass, General Purpose	70°C (158°F)
DPD1R1	Ryton ²	Convertible	Glass, General Purpose	70°C (158°F)
DPD1R3	Ryton ²	Convertible	Glass, HF-resistant	70°C (158°F)
DPS1	Stainless Steel	Immersion	Glass, General Purpose	50°C (122°F)

¹Polyetheretherketone ²Polyphenylene Sulfide

ORP Sensors

<u>Product Number</u>	<u>Body Material</u>	<u>Body Style</u>	<u>Electrode Material</u>	<u>Max Temp</u>
DRD1P5	PEEK ¹	Convertible	Platinum	70°C (158°F)
DRD1P6	PEEK ¹	Convertible	Gold	70°C (158°F)
DRD2P5	PEEK ¹	Insertion	Platinum	70°C (158°F)
DRD1R5	Ryton ²	Convertible	Platinum	70°C (158°F)
DRD1R6	Ryton ²	Convertible	Gold	70°C (158°F)
DRS5	Stainless Steel	Immersion	Platinum	50°C (122°F)

¹Polyetheretherketone ²Polyphenylene Sulfide

Digital Gateway

6120500 Digital Gateway, convert pHD analog sensors to digital output for connecting to sc100 digital controller

pHD Analog Sensors

All analog sensors include built-in preamplifier and integral 4.5 m (15 ft.) cable terminated with stripped and tinned wires.

Definitions of body styles:

- *Convertible* – 1-inch NPT threads at both ends, designed for tee-mounting or other flow through mountings, and pipe mounting for immersion
- *Insertion* – has no threads on the electrode end, designed for use with insertion valve assembly
- *Sanitary* – has a 2-inch flange for a Tri-Clover style fitting

pH Sensors

<u>Product Number</u>	<u>Body Material</u>	<u>Body Style</u>	<u>Electrode Material</u>	<u>Max Temp</u>
PD1P1	PEEK ¹	Convertible	Glass, General Purpose	95°C (203°F)
PD1P3	PEEK ¹	Convertible	Glass, HF-resistant	95°C (203°F)
PD2P1	PEEK ¹	Insertion	Glass, General Purpose	95°C (203°F)
PD3P1	PEEK ¹	Sanitary	Glass, General Purpose	95°C (203°F)
PD1R1	Ryton ²	Convertible	Glass, General Purpose	95°C (203°F)
PD1R3	Ryton ²	Convertible	Glass, HF-resistant	95°C (203°F)

¹Polyetheretherketone ²Polyphenylene Sulfide

ORP Sensors

<u>Product Number</u>	<u>Body Material</u>	<u>Body Style</u>	<u>Electrode Material</u>	<u>Max Temp</u>
RD1P5	PEEK ¹	Convertible	Platinum	95°C (203°F)
RD1P6	PEEK ¹	Convertible	Gold	95°C (203°F)
RD2P5	PEEK ¹	Insertion	Platinum	95°C (203°F)
RD1R5	Ryton ²	Convertible	Platinum	95°C (203°F)
RD1R6	Ryton ²	Convertible	Gold	95°C (203°F)

¹Polyetheretherketone ²Polyphenylene Sulfide

Ordering Information *continued*

pHD sc Digital and pHD Analog Sensor Accessories

Cables

Extension cables are used only with digital sensors or digital gateways when connecting to the sc100 Digital Controller.

61224-00	Digital Extension Cable, 1 m (3.2 ft.)
57960-00	Digital Extension Cable, 7.7 m (25 ft.)
57961-00	Digital Extension Cable, 15 m (50 ft.)
57962-00	Digital Extension Cable, 31 m (100 ft.)

Interconnect cables are used only with analog sensors, junction box, and controller.

1W11-00	Analog Interconnect Cable, order per foot
----------------	---

Digital Termination Box

Required when the length of cable between the digital sensor/digital gateway and sc100 Digital Controller is between 100 m (328 ft.) and 1000 m (3280 ft.)

58670-00	Digital Termination Box
-----------------	-------------------------

Analog Junction Box

Required when the length of cable between the analog sensor and analog controller is greater than standard length of sensor cable. Each junction box includes terminal strip and gasket.

60A2053	Junction Box, Surface-mount, aluminum (includes mounting hardware)
60A9944	Junction Box, Pipe-mount, PVC (for 1/2-inch diameter pipe, includes mounting hardware)
60G2052	Junction Box, Pipe-mount, PVC (for 1-inch diameter pipe, includes mounting hardware)
76A4010-001	Junction Box, NEMA 4X (no mounting hardware included)

Protector for Convertible style sensor

1000F3374-002	PEEK protector
1000F3374-003	Ryton protector

Salt Bridges

The double junction salt bridge on the standard cell of all Hach pHD sensors is field-replaceable. Each salt bridge has a ceramic inner junction, Viton® O-ring, and contains binary, equi-transferrant fill solution. Salt bridges are shipped in a salt solution.

<i>Product Number</i>	<i>pHD sc and pHD Sensor Body Material</i>	<i>Salt Bridge Materials</i>	
		<i>Body</i>	<i>Outer Junction</i>
SB-P1SV	PEEK	PEEK	Kynar (PVDF)
SB-P2SV	PEEK	PEEK	Ceramic
SB-P1SP¹	PEEK	PEEK	Kynar (PVDF)
SB-R1SV	Ryton	Ryton	Kynar (PVDF)

¹Special perfluoroelastomer O-ring in place of the Viton® O-ring

Cleaning Systems for pHD sc and pHD Sensors

Self-Contained Air Blast Cleaning System

Includes Kynar® (PVDF) washer head with 7.6 m (25 ft.) tubing for air delivery, a quick-disconnect tube fitting, and a compressor housed in a NEMA 4X enclosure.

1000A3335-005 For 115 VAC operation

1000A3335-006 For 230 VAC operation

Air/Water Blast Cleaning Washer Head

Intended only for immersion applications with a user-supplied air or water wash system.

1000A3335-004 Kynar (PVDF) washer head includes 1/4-inch barb fitting

pHD sc Digital and pHD Analog Sensor Reagents and Standards

25M1A1025-115 Standard Cell Solution, to replenish standard cell chamber in Hach pHD sensors while replacing salt bridge, 500 mL

25M8A1002-101 Gel Powder, for high temperature applications, 2 g

pH Buffers

<i>Product Number</i>	<i>Description</i>	<i>Volume</i>
22835-49	pH 7	500 mL (1 pint)
22834-49	pH 4	500 mL (1 pint)
22836-49	pH 10	500 mL (1 pint)

ORP Reference Solutions (in resealable plastic bottles)

<i>Product Number</i>	<i>Description</i>	<i>Volume</i>
25M2A1001-115	200 mV	500 mL (1 pint)
25M2A1002-115	600 mV	500 mL (1 pint)

Ordering Information *continued*

Mounting Hardware for pH/DO sc Differential Sensors

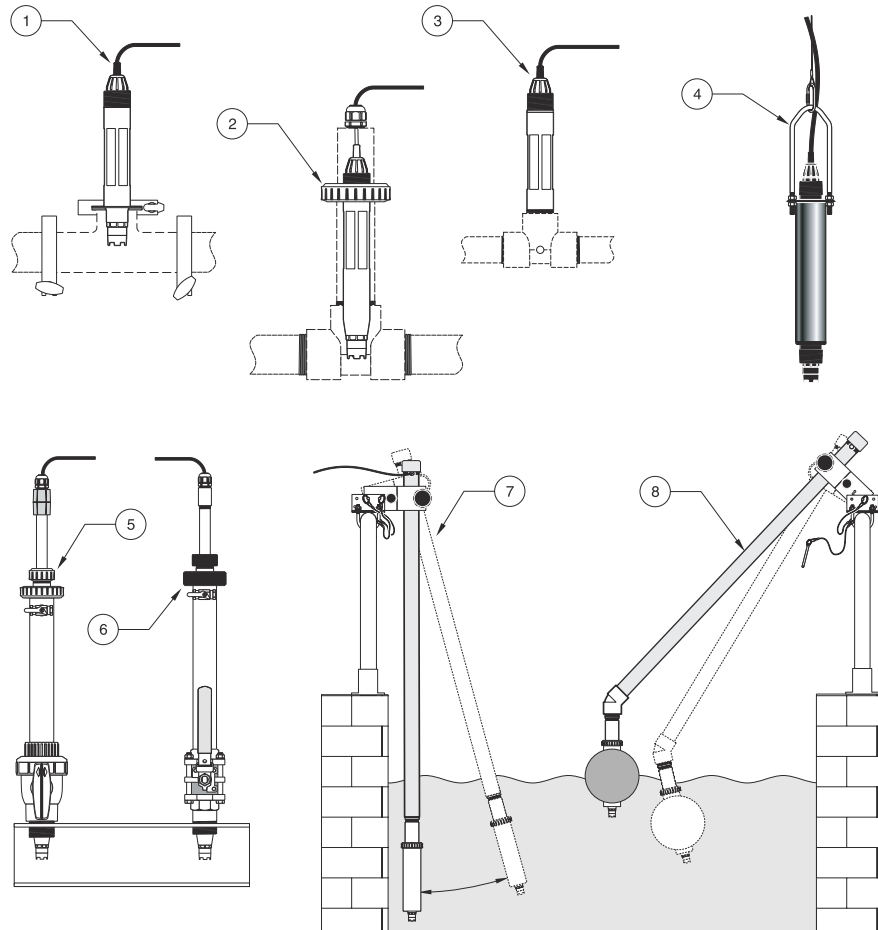

1. Sanitary mount
2. Union mount

3. Flow-through mount
4. Hanging stainless steel sensor with the bail

5. PVC Insertion mount
6. Stainless steel insertion mount

7. Immersion mount
8. Immersion mount, ball float

Sanitary Mount

MH018S8SZ 316 SS
Includes 2-inch sanitary tee and heavy-duty clamp. Special cap and EPDM compound gasket are supplied with sensor but can be separately ordered.

Union Mount

61313-00 CPVC
61314-00 316 SS
Includes standard 1-1/2 inch tee, special union pipe with adapter, sealing hub, and lock ring in respective material, and Viton® O-ring.

Flow-through Mount

MH334N4NZ CPVC
MH314N4MZ 316 SS
Includes a standard 1-inch tee in respective material.

Insertion Mount

Digital
61367-00 CPVC
61368-00 316 SS
Analog
MH736M4MZ CPVC
MH716M4MZ 316 SS
Includes a 1-1/2 inch ball valve in respective material, 1-1/2 inch NPT close nipple, sensor adapter with two Viton® O-rings and wiper, extension pipe, pipe adapter, back tube, and lock ring.

Immersion Mount

Standard Hardware

<i>Digital</i>		<i>Analog</i>	
61364-00	CPVC	MH434A00B	CPVC
61365-00	316 SS	MH414A00B	316 SS

Includes 1-inch diameter by 4 ft. long pipe and 1-inch x 1-inch NPT coupling in respective material. (Pipe-mount junction box with terminal strip included in analog hardware.)

Handrail Hardware

MH236B00Z CPVC
Includes 1-1/2 inch diameter by 7.5 ft. long CPVC pipe, and a unique swivel/pivot/ pipe clamp assembly.

Chain Mount Hardware

2881900 316 ss
Includes stainless steel bail, nuts, and washers. Does not include chain. To be used with stainless steel immersion sensor only.

NOTE

Contact Hach Technical Support or your Hach representative for information about retro fit hardware for existing installations.

To complete your pH and ORP measurement system, choose the sc100 or the sc1000 controller...

Model sc100 Controller

(see Lit. #2463)

- LXV401.52.00002** sc100 Controller Standard
LXV401.52.01002 sc100 Controller with RS-232 MODBUS®
LXV401.52.02002 sc100 Controller with RS-485 MODBUS®



Model sc1000 Controller

(see Lit. #2403)

- LXV402.99.00002** sc1000 Display Module
LXV400.99.1R572 sc1000 Probe Module, 4 sensors, 4 mA Out, 4 mA In, 4 Relays, 110-230V
LXV400.99.1B572 sc1000 Probe Module, 4 sensors, 4 mA Out, 4 mA In, 4 Relays, RS-485 (MODBUS), 110-230V
LXV400.99.1F572 sc1000 Probe Module, 4 sensors, 4 mA Out, 4 mA In, 4 Relays, PROFIBUS DP, 110-230V
LXV400.99.1R582 sc1000 Probe Module, 6 sensors, 4 mA Out, 4 mA In, 4 Relays, 110-230V



At Hach, it's about learning from our customers and providing the right answers. It's more than ensuring the quality of water—it's about ensuring the quality of life. When it comes to the things that touch our lives...

Keep it pure.

Make it simple.

Be right.

For current price information, technical support, and ordering assistance, contact the Hach office or distributor serving your area.

In the United States, contact:

HACH COMPANY World Headquarters
 P.O. Box 389
 Loveland, Colorado 80539-0389
 U.S.A.
 Telephone: 800-227-4224
 Fax: 970-669-2932
 E-mail: orders@hach.com
www.hach.com

U.S. exporters and customers in Canada, Latin America, sub-Saharan Africa, Asia, and Australia/New Zealand, contact:

HACH COMPANY World Headquarters
 P.O. Box 389
 Loveland, Colorado 80539-0389
 U.S.A.
 Telephone: 970-669-3050
 Fax: 970-461-3939
 E-mail: intl@hach.com
www.hach.com

In Europe, the Middle East, and Mediterranean Africa, contact:

HACH + LANGE Europe
 Dr. Bruno Lange GmbH & Co. KG
 Willstätterstraße 11
 D-40549 Düsseldorf
 GERMANY
 Tel: +49 (0) 211 5288-0
 Fax: +49 (0) 211 5288-143
 E-mail: info@hach-lange.de
www.hach-lange.com

Lit. No. 2467

B53 Printed in U.S.A.

©Hach Company, 2005. All rights reserved.

In the interest of improving and updating its equipment, Hach Company reserves the right to alter specifications to equipment at any time.



Be Right™