

Model P53 pH and ORP Analyzer

pH/ORP

GLI
International
A Hach Company Brand



Hach's GLI pH/ORP Analyzers and Transmitters are menu configurable, and accept GLI patented Differential Sensors as well as combination electrodes or electrode pairs. Models are available with predictive diagnostics that report electrode condition and sensor life.

DW

WW

PW

IW

E

C

FB

Features and Benefits

Large Backlit LCD Readout

The large display shows measured pH (or ORP) in 1/2-inch (13 mm) high numerals. The P53 can also display the process temperature, and both analog outputs. Display screen annunciators indicate relay "on/off" status.

Universal-mount 1/2 DIN Case

The P53 is housed in a 1/2 DIN, epoxy-coated, metal NEMA 4X case. Its hinged front panel provides easy wiring access. The supplied bracket and stainless steel hardware enable panel, surface, and pipe mounting.

Electromagnetic Conformance

The analyzer exceeds U.S. and meets European standards for EMI and RFI.

Simple Interactive Diagnostics

Built-in diagnostics continuously tests analyzer and sensor operation.

Multiple Language Capability

All screens can be selected for display in English, French, German or Spanish. Other available languages can be substituted.

"Menu-guided" Operation

The large display, simple keypad, and logical menu structure make the P53 easy to use. Menu screens, containing up to six text lines, guide you through setup, calibration, operation, and test/maintenance functions.

Passcode-protected Access

For security, use the P53's passcode capability to restrict access to configuration settings and calibration to authorized personnel only.

GLI Differential Sensor or Conventional Combination Electrode Compatibility

The Model P53 can be used with any GLI Differential Technique pH or ORP sensor, or any conventional combination electrode. The P53 accepts Pt 1000 RTD, Pt 100 RTD, or NTC 300 ohm thermistor temperature compensators.

Two 0/4-20 mA Analog Outputs

Each of the two isolated analog outputs can be set to 0-20 mA or 4-20 mA, and assigned to represent the measured pH (or ORP) or temperature. During calibration, both outputs can be held at their present values, transferred to preset values, or remain active to respond to the measured value.

DW = drinking water WW = wastewater municipal PW = pure water / power
IW = industrial water E = environmental C = collections FB = food and beverage



Be Right™

Specifications*

Operational

Display

Graphic dot matrix LCD, 128 x 64 pixels with LED backlighting; 1/2 inch (13 mm) main character height; 1/8 inch (3 mm) auxiliary information character height; menu screens contain up to six text lines

| Measurement | Selectable Ranges |
|-----------------------------|---|
| pH | -2.0 to 14.0 pH or -2.00 to 14.00 pH |
| ORP | -2100 to +2100 mV |
| Temperature | -4.0 to 392.0°F or -20.0 to 200.0°C |
| Analog Outputs (1 and 2) | 0.00-20.00 mA or 4.00-20.00 mA |

Ambient Conditions

Operation:

-4 to 140°F (-20 to 60°C); 0 to 95% relative humidity, non-condensing

Storage:

-22 to 158°F (-30 to 70°C); 0 to 95% relative humidity, non-condensing

Relays

Types/Outputs:

Four electromechanical relays; SPDT (Form C) contacts; U.L. rated 5A 115/230 Vac, 5A @ 30 Vdc resistive

Operational Mode:

Each relay (A, B, C, and D) can be assigned to be driven by the measured pH (or ORP) or temperature

Function Modes:

Control

Settings for high/low phasing, setpoint, deadband, overfeed timer, off delay, and on delay

Alarm

Settings for low alarm point, low alarm point deadband, high alarm point, high alarm point deadband, off delay, and on delay

Status

Not configurable; relay only activates when a "fail" diagnostic WARNING condition exists

Timer

Relay is activated by user-set interval and time duration to control a GLI sensor cleaning system

Indicators:

Relay annunciators (A, B, C, and D) indicate respective relay status

Temperature Compensation

Automatic from 14.0 to 230.0°F (-10.0 to 110.0°C) with selection for NTC 300 ohm thermistor (used in GLI Differential sensors), Pt 1000 ohm RTD or Pt 100 ohm RTD, or manually fixed at a user-entered temperature; additional selectable temperature correction factor available (ammonia, morpholine, or user-set pH/C linear slope) for pure water automatic compensation from 0.0 to 50.0°C

Sensor-to-Analyzer Distance

GLI Differential Technique Sensor:

3000 ft. (914 m) maximum

Conventional Combination Electrode with Preamplifier:

985 ft. (300 m) maximum

Conventional Combination Electrode without Preamplifier:

100 ft. (30 m) max. with electrode cable capacitance of less than 30 pF/foot

Power Requirements

90-130 Vac, 50/60 Hz. (10 VA max.)

or 180-260 Vac, 50/60 Hz. (10 VA max.)

Calibration Methods

2-point Buffer Method (pH only):

Automatic calibration and buffer recognition using two buffers from a selected buffer set.**

1-point Buffer Method (pH only):

Automatic calibration and buffer recognition using one buffer from a selected buffer set.**

**Buffer Sets: 4.00, 7.00, and 10.00 or DIN 19267 Standard (1.09, 4.65, 6.79, 9.23, and 12.75)

NOTE: When using buffers that are not included in either analyzer buffer set, calibrate using only the Sample Method (2 or 1-point).

2-point Sample Method (pH only):

Enter known values of two samples (determined by laboratory analysis or comparison reading) or two pH buffers.

1-point Sample Method (pH or ORP):

Enter known value of one sample (determined by laboratory analysis or comparison reading), one pH buffer or, for ORP measurement, one reference solution.

Analog Outputs

Two isolated 0/4-20 mA outputs; each with 0.004 mA (12-bit) resolution and capability to drive up to 600 ohm loads
NOTE: Each output can be assigned to represent the measured pH (or ORP) or temperature. Parameter values can be entered to define the endpoints at which the minimum and maximum mA output values are desired (range expand). During calibration, both outputs can be selected to hold their present values, transfer to preset values to operate control elements by an amount corresponding to those values, or remain active to respond to the measured value.

Communication

RS-232:

Enables configuration and retrieval of measured data for one analyzer using IBM-compatible PC and GLI optional software tool kit

Memory Backup (non-volatile)

All user settings are retained indefinitely in memory (EEPROM)

Certifications

European Community EMC:

Certified CE compliant for conducted and radiated emissions (EN 50081-2) and immunity (EN 61000-6-2)

General Purpose:

CSA/CSA_{NRTL} and FM (UL pending)

Class I, Div. 2 (Groups A, B, C, and D):

CSA/CSA_{NRTL} and FM (UL pending)

Analyzer Performance (Electrical, Analog Outputs)

Accuracy

0.1% of span

Stability

0.05% of span per 24 hrs., non-cumulative

Repeatability

0.1% of span or better

Temperature Drift

Zero: less than 0.03% of span per °C

Span: less than 0.03% of span per °C

Mechanical

Enclosure

NEMA 4X; polycarbonate face panel, epoxy-coated high-quality cast aluminum door and case with four 1/2-inch (13 mm) conduit holes, nylon mounting bracket, and stainless steel hardware

Mounting Configurations

Panel, surface, and pipe (horizontal and vertical) mounting

Net Weight

3.5 lbs. (1.6 kg) approximately

Engineering Specifications

- The microprocessor-based analyzer shall accept any GLI Differential Technique pH or ORP sensor, or any conventional combination electrode. The analyzer shall accept NTC 300 ohm thermistor, Pt 1000 RTD, and Pt 100 RTD temperature compensators.
- The analyzer shall be menu selectable to measure pH or ORP, and operate in multiple languages.
- The analyzer shall have a graphical dot matrix LCD display with 128 x 64 pixels and LED backlighting. The main display character height shall be 1/2 inch (13 mm). Auxiliary information character height shall be 1/8 inch (3 mm). Menu screens shall contain up to six text lines.
- The analyzer shall have these calibration methods:
 - 2-point Buffer Method (pH only): Automatic calibration and buffer recognition using two buffers from a selected buffer set
 - 1-point Buffer Method (pH only): Automatic calibration and buffer recognition using one buffer from a selected buffer set
 - 2-point Sample Method (pH only): Enter known values of two samples (determined by laboratory analysis or comparison reading) or two pH buffers.
 - 1-point Sample Method (pH and ORP): Enter known value of one sample (determined by laboratory analysis or comparison reading), one pH buffer or, for ORP measurement, one reference solution.
- The analyzer shall have a passcode to restrict access to configuration settings and calibration to authorized personnel only.
- The analyzer shall have user-test diagnostics for outputs, relays, and alarm annunciators without requiring special test equipment.
- The analyzer shall be configurable using its RS-232 port and optional GLI software tool kit.
- The analyzer shall have two isolated 0/4-20 mA analog outputs. Each output can be assigned to represent the measured pH (or ORP) or temperature. Parameter values can be entered to define the endpoints at which the minimum and maximum mA output values are desired. During calibration, both outputs can be selected to hold their present values, transfer to preset values to operate control elements by an amount corresponding to those values, or remain active to respond to the measured value.
- The analyzer shall be Hach Company, GLI Model P53 pH and ORP analyzer.

Dimensions

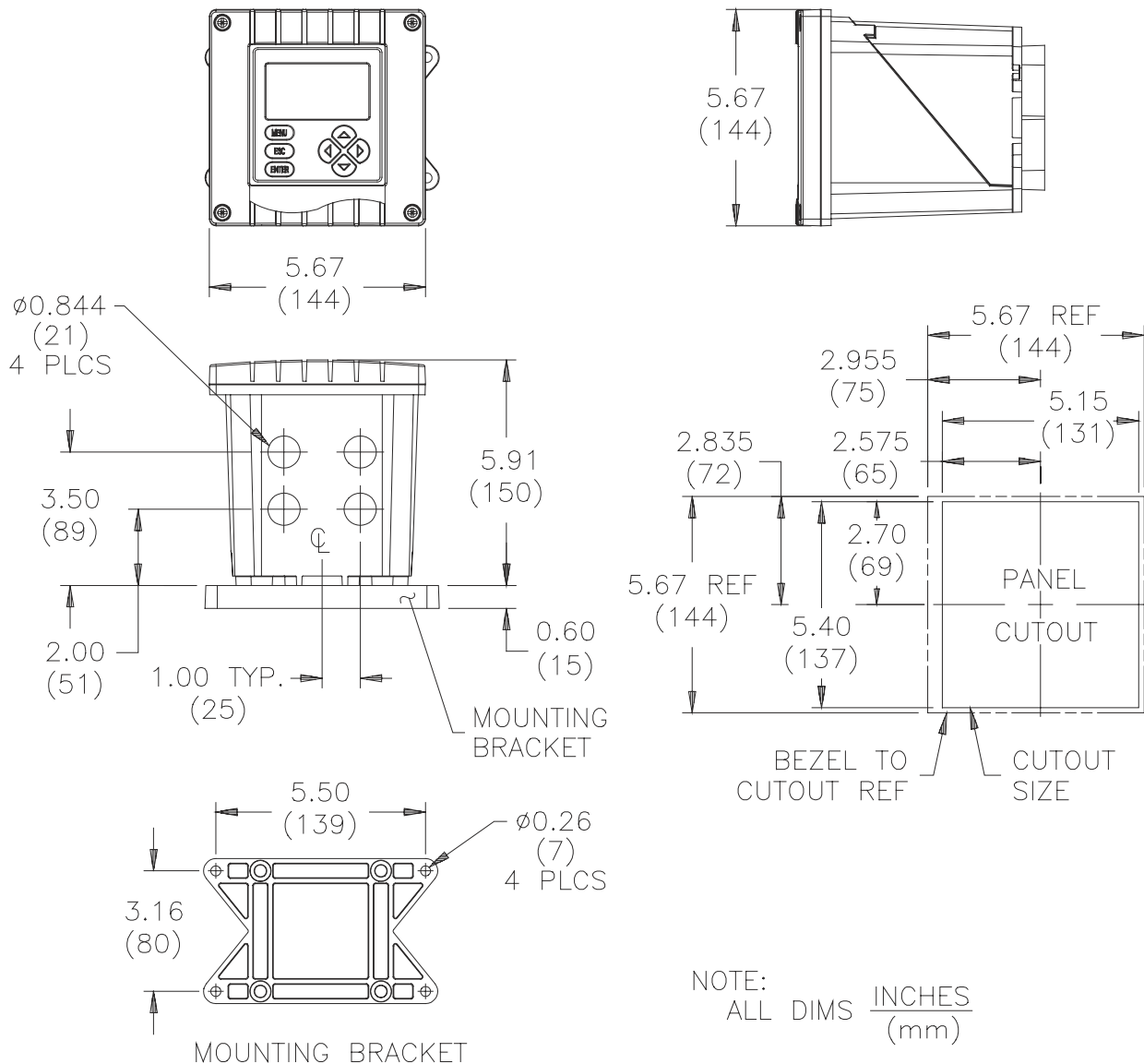

Ordering Information

All Hach Model P53 pH/ORP Controllers measure pH and ORP and are equipped with 4 electromechanical relays in a 1/2 DIN, NEMA 4X enclosure with hardware for panel, surface, or pipe mounting. (Comes with 2-year warranty.)

- P53A4A1N** Without tagging
P53A4A1P Paper tagging
P53A4A1S Stainless steel tagging

NOTE: When adding tagging, please provide the information you would like to have on the tag.

Accessories

- 1000G3311** Software Tool Kit
 The kit is for use with an IBM-compatible PC. The software can create and download multiple sets of analyzer configuration values. The kit includes a GLI software CD-ROM and ten-foot cable terminated with an RS-232 connector and stripped/tinned wires for connection to the analyzer.
- 1000G3088-001** Sun Shield
 Aluminum shield provides additional protection from harmful effects of direct sunlight.

GLI pH™ Differential pH and ORP Sensors

(see Lit. #G109)



Get unsurpassed accuracy with differential measurement technique. These sensors use three electrodes instead of the normal two in conventional pH sensors. A built-in preamplifier boosts high impedance signals to the electrodes for a strong signal up to 3000 feet away.

GLI 3/4-inch Combination pH and ORP Sensors

(see Lit. #G112)



GLI combination sensors are well suited for aggressive processes that require frequent probe replacement. Sensors are available with rugged dome electrodes, flat glass electrodes, and even hydrofluoric acid resistant glass electrodes. These sensors are specifically designed for specialty applications and come in a variety of mounting styles.

Lit. No. G104 (supercedes PR53/402)

XXXX Printed in U.S.A.

©Hach Company, 2004. All rights reserved.

In the interest of improving and updating its equipment, Hach Company reserves the right to alter specifications to equipment at any time.

At Hach, it's about learning from our customers and providing the right answers. It's more than ensuring the quality of water—it's about ensuring the quality of life. When it comes to the things that touch our lives...

Keep it pure.

Make it simple.

Be right.

For current price information, technical support, and ordering assistance, contact the Hach office or distributor serving your area.

In the United States, contact:

HACH COMPANY World Headquarters
 P.O. Box 389
 Loveland, Colorado 80539-0389
 U.S.A.
 Telephone: 800-227-4224
 Fax: 970-669-2932
 E-mail: orders@hach.com
www.hach.com

U.S. exporters and customers in Canada, Latin America, sub-Saharan Africa, Asia, and Australia/New Zealand, contact:

HACH COMPANY World Headquarters
 P.O. Box 389
 Loveland, Colorado 80539-0389
 U.S.A.
 Telephone: 970-669-3050
 Fax: 970-461-3939
 E-mail: intl@hach.com
www.hach.com

In Europe, the Middle East, and Mediterranean Africa, contact:

HACH + LANGE Europe
 Dr. Bruno Lange GmbH & Co. KG
 Willstätterstraße 11
 D-40549 Düsseldorf
 GERMANY
 Tel: +49 (0) 211 5288-0
 Fax: +49 (0) 211 5288-143
 E-mail: kundenservice@drlange.de
www.drlange.com



Be Right™