

# OPERATING INSTRUCTION MANUAL

## Model P53 pH/ORP Analyzer

(Universal-mount 1/2 DIN style;  
selectable for pH or ORP measurement)

### **Worldwide Headquarters and Sales:**

**GLI International, Inc.**      *Phone:* [414] 355-3601  
9020 West Dean Road      *Fax:* [414] 355-8346  
Milwaukee, Wisconsin 53224      *E-mail:* info@gliint.com  
U.S.A.      *Web:* www.gliint.com

### **Represented By:**

*In the interest of improving and updating its equipment, GLI reserves the right to alter specifications to equipment at any time.*

[gliint.com](http://gliint.com)

This operating manual and other GLI operating manuals are available on GLI's web site at [gliint.com](http://gliint.com) when viewed using Adobe's free Acrobat reader. To get this reader, link to Adobe through GLI's web site or visit Adobe's web site at [adobe.com](http://adobe.com).

# IMPORTANT SAFETY INFORMATION

**This analyzer is compliant with safety standards as outlined in:**

FMRC Class Numbers 3600, 3611, and 3810 (U.S.A.)  
CSA C22.2 No. 142 and C22.2 No. 213 (Canada)  
EN 61010-1 (European Community)

**Please read and observe the following:**

- Opening the analyzer door exposes you to line power voltage, if present, at terminals on TB2 and TB3 inside the enclosure. This may be hazardous. Always remove line power before entering this area in the analyzer. However, the analyzer door assembly contains only low voltage and is completely safe to handle.
- Install this analyzer in accordance with relevant local codes and instructions contained in this operating manual. Also, note and comply with the analyzer's technical specifications and input ratings. If one line of the line power mains is not neutral, use a double-pole mains switch to disconnect the analyzer.
- Whenever it appears that analyzer safety is questionable, disconnect line power from the analyzer to ensure against any unintended operation. For example, an unsafe condition is likely when:
  - 1) The analyzer appears visibly damaged.
  - 2) The analyzer fails to operate properly or provide the intended measurements.
  - 3) The analyzer has been stored for long periods at temperatures above 158°F (70°C).
- Only qualified personnel should perform wiring or repairs, and only when the analyzer is not powered.

## HELPFUL IDENTIFIERS

In addition to information on installation and operation, this instruction manual may contain WARNINGS pertaining to user safety, CAUTIONS regarding possible instrument malfunction, and NOTES on important, useful operating guidelines.

### WARNING:

**A WARNING LOOKS LIKE THIS. IT WARNS YOU OF THE POTENTIAL FOR PERSONAL INJURY.**

### CAUTION:

**A CAUTION LOOKS LIKE THIS. IT ALERTS YOU TO POSSIBLE INSTRUMENT MALFUNCTION OR DAMAGE.**

 **NOTE:** *A note looks like this. It alerts you to important operating information.*

## Definition of Equipment Symbols



This symbol **means CAUTION** and alerts you to possible danger or instrument malfunction. Refer to this manual before proceeding.



This symbol **means that this is a protective ground terminal** and alerts you to connect an earth ground to it.



This symbol **means that there is alternating current present** and alerts you to be careful.

## WARRANTY

GLI International, Inc. warrants the Model P53 to be free from defects in material or workmanship for a period of 2 years (24 months) from the date of shipment of this product from our facility. A warranty claim will not be honored if defects are not reported within the warranty period, or if GLI International determines that defects or damages are due to normal wear, misapplication, lack of maintenance, abuse, improper installation, alteration, or abnormal conditions. GLI International's obligation under this warranty shall be limited to, at its option, replacement or repair of this product. The product must be returned to GLI International, freight prepaid, for examination. The product must be thoroughly cleaned and any process chemicals removed before it will be accepted for replacement or repair. GLI International's liability shall not exceed the cost of the product. Under no circumstances will GLI International be liable for any incidental or consequential damages, whether to person or property. GLI International will not be liable for any other loss, damage or expense of any kind, including loss of profits, resulting from the installation, use, or inability to use this product.

## CONDENSED OPERATING INSTRUCTIONS

This manual contains details for all operating aspects of the instrument. The following condensed instructions are provided to assist you in getting the instrument started up and operating as quickly as possible. **These condensed instructions only pertain to basic pH measurement operation using a GLI Differential pH sensor.** To measure ORP, use a conventional combination electrode or use specific features of the instrument, refer to the appropriate sections in this manual for instructions.

### A. CONNECTING SENSOR/CONFIGURING SENSOR TYPE AND TEMPERATURE ELEMENT

1. After properly mounting the analyzer (PART TWO, Section 2), connect the GLI Differential Technique pH sensor, matching wire colors to terminals as indicated:

Sensor Wire Colors	Analyzers with "B" Prefix Serial No.	Analyzers with "A" or No Letter Prefix Serial No.
White	Terminal #13 on TB1	Terminal #13 on TB1
Black	Terminal #14 on TB1	Terminal #14 on TB1
Yellow	Terminal #16 on TB1	Terminal #16 on TB1
Shield	Terminal #18 on TB1	Terminal #11 on TB1
Green	Terminal #20 on TB1	Terminal #20 on TB1
Red	Terminal #22 on TB1	Terminal #22 on TB1

**NOTE:** For GLI Differential sensors that have two shield wires, always connect the outer shield to an earth ground terminal and the inner shield to the "shield" terminal.

2. The analyzer is factory-set to use a GLI Differential Technique pH sensor. To use a conventional combination electrode, you must change the sensor type (see PART THREE, Section 4.2, subheading "SELECT SENSOR Type").
3. The analyzer is factory-set for automatic temperature compensation using the NTC 300 ohm temperature element built into all GLI Differential sensors (except GLI's pure water pH sensor system 6006P4-2000 which uses a Pt 1000 RTD). When you want fixed MANUAL temperature compensation or if you are using a sensor with a different temperature element, you must change the temperature element type (see PART THREE, Section 4.2, subheading "Select TEMP ELEMENT Type").

### B. CONNECTING LINE POWER

**Important:** Follow instructions in PART TWO, Section 3.7 to connect line power to the analyzer.

### C. ADJUSTING DISPLAY CONTRAST

Ambient lighting conditions may make it necessary to adjust display contrast to improve visibility. With the MEASURE screen displayed, press and hold the **ENTER key** and simultaneously press the **↑ or ↓ key** until attaining the desired contrast.

### D. CONFIGURING BUFFER TYPE/CALIBRATING THE ANALYZER

The analyzer must be calibrated so that measured values will correspond to actual process values. Before calibrating for the first time, select the buffer set you intend to use. Then, calibrate using the recommended "2 POINT BUFFER" method which provides the most accurate pH measurements.

1. The analyzer is factory-set for the common 4.00, 7.00, and 10.00 pH buffer set. For DIN 19267 standard value buffers you must change the buffer set (see PART THREE,

(continued on next page)

# CONDENSED OPERATING INSTRUCTIONS

## D. CALIBRATING THE ANALYZER -- (continued)

Section 4.2, subheading “SELECT BUFFER Set for pH Calibration”).

**NOTE:** When using buffers that are not included in either of these buffer sets, use only the “2 POINT SAMPLE” method for calibration. Refer to that subheading in PART THREE, Section 5.2 for instructions.

2. Immerse the sensor in the first buffer (preferably pH 7). **Important: Allow the sensor and buffer temperatures to equalize.** Depending on their temperature differences, this may take 30 minutes or more.

**NOTE:** An in-progress calibration can always be aborted by pressing the **ESC** key. After the “ABORT: YES?” screen appears, do one of the following:

- Press **ENTER** key to abort. After “CONFIRM ACTIVE?” screen appears, press **ENTER** key again to display the MEASURE screen and return the analog outputs and relays to their active states.
- Use **↑** or **↓** key to choose “ABORT: NO?” screen, and press **ENTER** key to continue calibration.

**Calibration Tip!** If, at any time during calibration, the “2 POINT BUFFER: CONFIRM FAILURE?” screen appears, press **ENTER** key to confirm. Then, use the **↑** or **↓** key to select between “CAL EXIT” or “CAL REPEAT” and do one of the following:

- With the “2 POINT BUFFER: CAL: EXIT?” screen selected, press **ENTER** key. Then, after the “2 POINT BUFFER: CONFIRM ACTIVE?” screen appears, press **ENTER** key to return the analog outputs and relays to their active states (MEASURE screen appears).
- With the “2 POINT BUFFER: CAL REPEAT?” screen selected, press **ENTER** key to repeat calibration of this point.

3. Press **MENU** key to display

```
MAIN MENU
▶CALIBRATE
▶CONFIGURE
▶TEST/MAINT
◀EXIT
```

4. With the “CALIBRATE” line selected, press **ENTER** key to display

```
CALIBRATE
▶SENSOR
▶CAL OUTPUTS
◀EXIT
```

5. With the “SENSOR” line selected, press **ENTER** key to display

```
SENSOR
▶2 POINT BUFFER
▶1 POINT BUFFER
▶2 POINT SAMPLE
▶1 POINT SAMPLE
◀EXIT
```

(continued on next page)

## CONDENSED OPERATING INSTRUCTIONS

### D. CALIBRATING THE ANALYZER -- (continued)

6. With the “2 POINT BUFFER” line selected, press **ENTER key** to display 

2 POINT BUFFER? (HOLD OUTPUTS )
------------------------------------

.
7. Press **ENTER key** to “hold” the analog outputs and relays at their present states during calibration. (Outputs can also be transferred to preset values or allowed to remain active.)
8. With the sensor in the first buffer and the 

2 POINT BUFFER: IN 1ST SOLUTION?
-------------------------------------

 screen displayed, press **ENTER key** to confirm. While the 

2 POINT BUFFER: PLEASE WAIT
--------------------------------

 screen is displayed, the analyzer waits for the pH and temperature signals to stabilize, measures the buffer value, and automatically calibrates this point. Thereafter, a screen like 

2 POINT BUFFER: PT1 = 7.00 pH
----------------------------------

 appears for 5 seconds to confirm calibration of this point.

**NOTE:** Any time the “PLEASE WAIT” screen appears during calibration, you can manually complete calibration of the point by pressing the ENTER key. However, this is not recommended because the pH and temperature signals may not be fully stabilized, resulting in a less accurate calibration.

9. After the 

2 POINT BUFFER: IN 2ND SOLUTION?
-------------------------------------

 screen appears, remove the sensor from the first buffer, rinse it with clean water, and immerse it in the second buffer (typically pH 4). Then press **ENTER key** to confirm this.
10. While the 

2 POINT BUFFER: PLEASE WAIT
--------------------------------

 screen is displayed, the analyzer waits for the pH and temperature signals to stabilize, measures the buffer value, and automatically calibrates this point. Thereafter, a screen like 

2 POINT BUFFER: PT2 = 4.00 pH
----------------------------------

 appears for 5 seconds to confirm calibration of this point.
11. A “pH SLOPE XX.X mV/pH” screen appears, indicating a slope value to measure sensor performance. The slope should be 54-62 mV/pH for optimal performance.
12. Press **ENTER key** to end calibration (“2 POINT BUFFER: CONFIRM CAL OK?” screen appears).
13. Re-install the sensor into the process.
14. Press **ENTER key** to display the active measurement reading on the “2 POINT BUFFER: CONFIRM ACTIVE?” output status screen. When the reading corresponds to the actual typical process value, press **ENTER key** again to return the analog outputs and relays to their active states (MEASURE screen appears).

This completes “2 POINT BUFFER” calibration. The analyzer is now ready to measure pH.

### E. COMPLETING ANALYZER CONFIGURATION

To further configure the analyzer to your application requirements, use the appropriate CONFIGURE screens to make selections and “key in” values. Refer to PART THREE, Section 4 for complete configuration details.



# TABLE OF CONTENTS

## PART ONE - INTRODUCTION

<b>SECTION 1</b>	<b>GENERAL INFORMATION</b>	
	1.1 Capability Highlights .....	15-16
	1.2 Modular Construction .....	16-17
	1.3 Retained Configuration Values .....	17
	1.4 Analyzer Serial Number .....	17
	1.5 EMI/RFI Immunity .....	17
<b>SECTION 2</b>	<b>SPECIFICATIONS</b> .....	18-19

## PART TWO - INSTALLATION

<b>SECTION 1</b>	<b>UNPACKING</b> .....	20
<b>SECTION 2</b>	<b>MECHANICAL REQUIREMENTS</b>	
	2.1 Location .....	20
	2.2 Mounting .....	21-22
	2.3 Conduit Hole Requirements .....	22
<b>SECTION 3</b>	<b>ELECTRICAL CONNECTIONS</b>	
	3.1 GLI Differential Technique Sensor .....	23-25
	3.2 Conventional Combination Electrode .....	25-26
	3.3 Conventional Combination Electrode with Ground Rod .....	26
	3.4 Analog Outputs .....	27
	3.5 Relay Outputs .....	28
	3.6 Closed Contact TTL Input .....	29
	3.7 Line Power .....	30-31

## PART THREE - OPERATION

<b>SECTION 1</b>	<b>USER INTERFACE</b>	
	1.1 Display .....	32
	1.2 Keypad .....	32-33
	1.3 MEASURE Screen (normal display mode) .....	34
<b>SECTION 2</b>	<b>MENU STRUCTURE</b>	
	2.1 Displaying Main Branch Selection Screen .....	35
	2.2 Displaying Top-level Menu Screens .....	35-36
	2.3 Displaying Submenu Screens .....	36
	2.4 Adjusting Edit/Selection Screen Values .....	36
	2.5 Entering (Storing) Edit/Selection Screen Values/Choices .....	36

# TABLE OF CONTENTS (continued)

<b>SECTION 3</b>	<b>ADJUSTING DISPLAY CONTRAST</b> .....	37
<b>SECTION 4</b>	<b>ANALYZER CONFIGURATION</b>	
4.1	Selecting LANGUAGE to Operate Analyzer.....	37
4.2	Configuring Sensor Characteristics:	
	SELECT SENSOR Type .....	38
	Select DISPLAY FORMAT .....	39
	SELECT BUFFER Set for pH Calibration .....	39
	Select PURE H2O COMP (for special applications) .....	40
	SET ISO POINT (isopotential for special Differential pH sensor) .....	41
	SET FILTER Time.....	41-42
	Select PULSE SUPPRESS (on/off).....	42
	ENTER NOTE (top line of MEASURE screen).....	42-43
	Select TEMP ELEMENT Type .....	43-44
4.3	SET °C OR °F (temperature display format) .....	44-45
4.4	Configuring Analog Outputs (1 and 2):	
	SET PARAMETER (representation) .....	45-46
	SET 0/4 mA and 20 mA VALUES (range expand) .....	46-47
	SET TRANSFER Value (mA) .....	47
	SET FILTER Time.....	48
	Select SCALE 0 mA/4 mA (low endpoint) .....	48
4.5	Configuring Relays (A, B, C, and D):	
	SET PARAMETER (representation) .....	49-50
	SET FUNCTION Mode (alarm, control, timer or status).....	50-51
	SET TRANSFER Mode (relay on or off) .....	51
	ACTIVATION (configuration values).....	52-53
4.6	SET PASSCODE (feature enabled or disabled) .....	54
4.7	Configuration Setting Summary (ranges/choices and defaults) .....	55-56
<b>SECTION 5</b>	<b>ANALYZER CALIBRATION</b>	
5.1	Important Information	
	Calibrate Periodically .....	57
	Temperature-corrected pH Measurement.....	57
5.2	pH Calibration:	
	2 POINT BUFFER Method.....	58-60
	1 POINT BUFFER Method.....	61-62
	2 POINT SAMPLE Method.....	63-65
	1 POINT SAMPLE Method.....	65-67
5.3	ORP Calibration .....	67-69
5.4	Analog Outputs (1 and 2) Calibration.....	69-70

# TABLE OF CONTENTS (continued)

<b>SECTION 6</b>	<b>TEST/MAINTENANCE</b>	
	6.1 STATUS Checking (analyzer, sensor, and relays).....	71-72
	6.2 HOLD OUTPUTS .....	73
	6.3 OVERFEED RESET (relay timers).....	73
	6.4 OUTPUT (1 and 2) Analog Test Signals .....	74
	6.5 RELAY (A, B, C, and D) Operating Test.....	74-75
	6.6 EPROM VERSION Checking .....	75
	6.7 SELECT SIM Measurement .....	75-76
	6.8 SIM SENSOR Setting.....	76
	6.9 RESET CONFIG Values to Factory Defaults .....	76-77
	6.10 RESET CAL Values to Factory Defaults .....	77
<b>SECTION 7</b>	<b>RELAY OVERFEED TIMER FEATURE</b>	
	7.1 Why Use an Overfeed Timer.....	78
	7.2 Configuring Relay Overfeed Timers.....	78
	7.3 Overfeed Timer “Timeout” Operation .....	78
	7.4 Resetting Overfeed Timers .....	78
	7.5 Interactions with Other Analyzer Functions.....	78-79
<b>SECTION 8</b>	<b>HART OPTION</b>	
	8.1 Introduction .....	80
	8.2 Analyzer Operating Modes for HART Network.....	81-82
	8.3 SINGLE MODE (Point-to-Point) Wiring Arrangement .....	82
	8.4 MULTI-DROP Wiring Arrangement.....	83
	8.5 HART Preferences Setup:	
	Changing Polling Address .....	84
	Viewing Number of Required Preambles .....	84-85
	8.6 Device Preferences Setup:	
	Viewing Final Assembly Number .....	85
	Viewing Model Number .....	85-86
	Viewing Manufacturer .....	86
	Assigning a Tag .....	86
	Assigning a Descriptor .....	87
	Assigning a Message .....	87
	Assigning User-defined Date .....	87-88
	Viewing Identification (ID) .....	88
	Viewing Revisions.....	88
	8.7 “Master Reset” Function.....	89
	8.8 “Refresh” Function .....	89
	8.9 Protocol Command Set for PC Programming.....	89

# TABLE OF CONTENTS (continued)

## PART FOUR - SERVICE AND MAINTENANCE

<b>SECTION 1</b>	<b>GENERAL INFORMATION</b>	
	1.1 Inspecting Sensor Cable .....	90
	1.2 Replacing Fuse(s) .....	90
	1.3 Replacing Relays .....	90
<b>SECTION 2</b>	<b>PRESERVING MEASUREMENT ACCURACY</b>	
	2.1 Keeping Sensor Clean .....	91
	2.2 Keeping Analyzer Calibrated.....	91
	2.3 Avoiding Electrical Interference.....	91
<b>SECTION 3</b>	<b>TROUBLESHOOTING</b>	
	3.1 Ground Loops:	
	Determining If Ground Loop Exists .....	92
	Finding Source of Ground Loop.....	93
	3.2 Isolating Measuring System Problem:	
	Checking Electrical Connections .....	93
	Verifying Sensor Operation.....	93
	Verifying Analyzer Operation .....	93-95
	Verifying Interconnect Cable Integrity.....	95
<b>SECTION 4</b>	<b>ANALYZER REPAIR/RETURN</b>	
	4.1 Customer Assistance.....	96
	4.2 Repair/Return Policy .....	96

## PART FIVE - SPARE PARTS AND ACCESSORIES

.....	97
-------	----

# TABLE OF CONTENTS (continued)

## ILLUSTRATIONS

<b>Figure 1-1</b>	EMI/RFI Immunity Diagram .....	17
<b>Figure 2-1</b>	Analyzer Mounting Arrangements .....	21
<b>Figure 2-2</b>	Analyzer Installation Dimension Details .....	22
<b>Figure 2-3</b>	Terminal Designations for Analyzers with “B” Prefix Serial Number .....	24
<b>Figure 2-4</b>	Terminal Designations for Analyzers with “A” or No Letter Prefix Serial Number.....	24
<b>Figure 2-5</b>	Connecting GLI Differential Technique Sensor to Analyzers with “B” Prefix Serial Number.....	25
<b>Figure 2-6</b>	Connecting GLI Differential Technique Sensor to Analyzers with “A” or No Letter Prefix Serial Number .....	25
<b>Figure 2-7</b>	Connecting Conventional Combination Electrode to Analyzers with “B” Prefix Serial Number.....	25
<b>Figure 2-8</b>	Connecting Conventional Combination Electrode to Analyzers with “A” or No Letter Prefix Serial Number .....	25
<b>Figure 2-9</b>	Connecting Conventional Combination Electrode with Ground Rod to Analyzers with “B” Prefix Serial Number .....	26
<b>Figure 2-10</b>	Connecting Conventional Combination Electrode with Ground Rod to Analyzers with “A” or No Letter Prefix Serial Number .....	26
<b>Figure 2-11</b>	Connecting Control/Alarm Device(s) to Electromechanical Relay(s) .....	28
<b>Figure 2-12</b>	Connecting 115 V Single Phase to Analyzers with “B” Prefix Serial Number .....	30
<b>Figure 2-13</b>	Connecting 230 V Single Phase to Analyzers with “B” Prefix Serial Number .....	30
<b>Figure 2-14</b>	Connecting 230 V Split Phase to Analyzers with “B” Prefix Serial Number.....	30
<b>Figure 2-15</b>	Connecting 115 V Single Phase to Analyzers with “A” or No Letter Prefix Serial Number....	31
<b>Figure 2-16</b>	Connecting 230 V Single Phase to Analyzers with “A” or No Letter Prefix Serial Number....	31
<b>Figure 2-17</b>	Connecting 230 V Split Phase to Analyzers with “A” or No Letter Prefix Serial Number .....	31
<b>Figure 3-1</b>	Analyzer Keypad .....	33
<b>Figure 3-2</b>	Location of Analyzer SINGLE MODE/MULTI-DROP Switch.....	82
<b>Figure 3-3</b>	HART SINGLE MODE (Point-to-Point) Wiring Arrangement (for single analyzer) .....	82
<b>Figure 3-4</b>	HART MULTI-DROP Wiring Arrangement (for multiple analyzer network) .....	83

## TABLES

<b>Table A</b>	Relay Configuration Settings .....	52
<b>Table B</b>	Analyzer Configuration Settings (Ranges/Choices and Defaults) .....	55-56
<b>Table C</b>	Relay Overfeed Timer Interactions with Other Analyzer Functions.....	79



# PART ONE - INTRODUCTION

## SECTION 1

### GENERAL INFORMATION

#### 1.1 Capability Highlights

Sensor Input	<p>The analyzer can be used with any GLI Differential Technique pH or ORP sensor, or any conventional combination electrode. The analyzer accepts the common temperature compensator elements used in these sensors (NTC 300 ohm thermistor, Pt 1000 RTD or Pt 100 RTD).</p>
MEASURE Screen	<p>The MEASURE screen (normal display mode) can provide different readouts of measured data. Measured pH (or ORP) is always shown on the main middle line. The bottom auxiliary display line, shown in reverse video, can be changed by pressing the <b>↓</b> and <b>↑</b> keys to show:</p> <ul style="list-style-type: none"> <li>• Measured temperature (°C or °F)</li> <li>• Analog Output 1 value (mA)</li> <li>• Analog Output 2 value (mA)</li> </ul>
Passcode-protected Access	<p>For security, you can enable a passcode feature to restrict access to configuration and calibration settings to authorized personnel only. See PART THREE, Section 4.6 for details.</p>
Calibration Methods	<p>Four methods are available to calibrate the analyzer for pH. See PART THREE, Section 5.2 for details. For ORP calibration, refer to Section 5.3. Each analog output mA value can also be calibrated (Section 5.4).</p>
Analog Outputs	<p>The analyzer provides two isolated analog outputs (1 and 2). Each output can be set to be 0-20 mA or 4-20 mA, and assigned to represent <u>one</u> of these measurements:</p> <ul style="list-style-type: none"> <li>• Measured pH (or ORP)</li> <li>• Measured temperature</li> </ul> <p>Parameter values can be entered to define the endpoints at which the minimum and maximum analog output values are desired (range expand). For analog output setup details, refer to PART THREE, Section 4.4.</p>

During calibration, both analog outputs can be selected to:

- Hold their present values (HOLD OUTPUTS).
- Transfer to preset values to operate control elements by an amount corresponding to those values (XFER OUTPUTS).
- Remain active to respond to the measured value (ACTIVE OUTPUTS).

## Relays

The analyzer may have up to four electromechanical relays, all with SPDT contacts. Each relay can be set to function as a CONTROL, ALARM, STATUS or TIMER relay. CONTROL and ALARM relays can be assigned to be driven by the measured pH (or ORP) or measured temperature.



**NOTE:** *Since TIMER and STATUS relays are driven by other criteria, the parameter assigned to these relays is not relevant and, therefore, disregarded.*

Refer to PART THREE, Section 4.5 for relay setup details.



**NOTE:** *When a relay is set to function as a STATUS relay, it is no longer configurable. Instead, it becomes a dedicated system diagnostic-only alarm relay that automatically energizes when the “WARNING CHECK STATUS” message flashes on the MEASURE screen. This occurs when the analyzer detects a “fail” diagnostic condition. See PART THREE, Section 6.1 for more details.*

Except for STATUS relays, during calibration the relay on/off states are affected in the same way as the analog outputs by the “(HOLD/XFER/ACTIVE) OUTPUTS” screen selection. These relays are also held at their present on/off states, transferred to desired preset on/off states, or remain active to respond to measured values.

## 1.2 Modular Construction

The modular construction of the analyzer simplifies field servicing and provides electrical safety. The front door/keypad assembly uses voltages no greater than 24 VDC, and is completely safe to handle.

Opening the analyzer door accesses terminals inside the enclosure for electrical connections. Line power must be connected to specifically designated terminals on TB3.

**WARNING:**  
**REMOVE LINE POWER BEFORE NEARING THIS AREA TO AVOID ELECTRICAL SHOCK.**

**1.3 Retained Configuration Values**

All user-entered configuration values are retained indefinitely, even if power is lost or turned off. The non-volatile analyzer memory does not require battery backup.

**1.4 Analyzer Serial Number**

A label with the analyzer model number, serial number, build date, and other items is affixed to the top of the enclosure.

**1.5 EM/RFI Immunity**

The analyzer is designed to provide protection from most normally encountered electromagnetic interference. This protection exceeds U.S. standards and meets European IEC 801-series testing for electromagnetic and radio frequency emissions and susceptibility. Refer to Figure 1-1 and the specifications in Section 2.1 for more information.

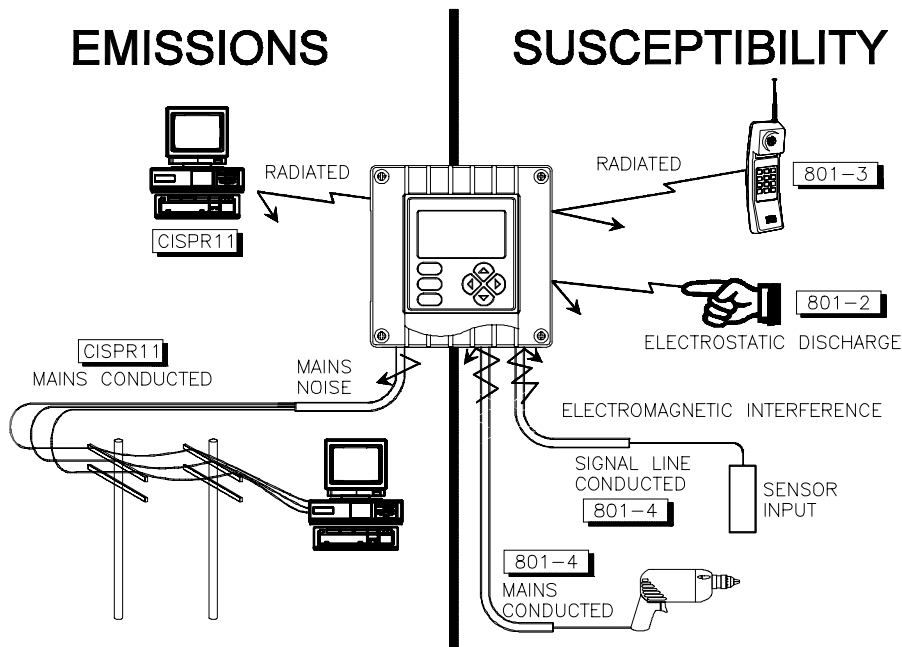

FIGURE 1-1 EMI/RFI Immunity Diagram

## SECTION 2

## SPECIFICATIONS

## 2.1 Operational

Display.....	Graphic dot matrix LCD, 128 x 64 pixels with LED backlighting; 1/2 inch (13 mm) main character height; 1/8 inch (3mm) auxiliary information character height; menu screens contain up to six text lines
<u>Measurement</u>	<u>Selectable Ranges</u>
pH.....	-2.0 to 14.0 pH or -2.00 to 14.00 pH
ORP.....	-2100 to +2100 mV
Temperature .....	-20.0 to +200.0°C or -4.0 to +392.0°F
Analog Outputs (1 and 2) .....	0.00-20.00 mA or 4.00-20.00 mA
Ambient Conditions:	
Operation.....	-4 to +140°F (-20 to +60°C); 0-95% relative humidity, non-condensing
Storage.....	-22 to +158°F (-30 to +70°C); 0-95% relative humidity, non-condensing
Relays: Types/Outputs .....	Up to four electromechanical relays; SPDT (Form C) contacts; U.L. rated 5A 115/230 VAC, 5A @ 30 VDC resistive
Operational Mode.....	Each relay (A, B, C, and D) can be driven by the measured pH (or ORP) or temperature
Function Modes:	
Control .....	Settings for high/low phasing, setpoint, deadband, overfeed timer, off delay, and on delay
Alarm.....	Settings for low alarm point, low alarm point deadband, high alarm point, high alarm point deadband, off delay, and on delay
Status.....	Not configurable; relay only activates when a sensor or analyzer "fail" diagnostic WARNING condition exists
Timer.....	Relay is activated by user-entered interval and time duration values to control GLI cleaning system
Indicators .....	Relay annunciators (A, B, C, and D) indicate respective relay on/off status
Temperature Compensation .....	Automatic from 14.0 to 230.0°F (-10.0 to +110.0°C) with selection for NTC 300 ohm thermistor, Pt 1000 ohm RTD or Pt 100 ohm RTD temperature element, or manually fixed at a user-entered temperature; additional selectable temperature correction factors (ammonia, morpholine or user-defined pH/°C linear slope) available for pure water automatic compensation from 0.0 to 50.0°C
Sensor-to-Analyzer Distance:	
GLI Differential	
Technique Sensor.....	3000 ft. (914 m) maximum
Conventional Combination	
Electrode with preamp .....	985 ft. (300 m) maximum
Conventional Combination	
Electrode without preamp ..	100 ft. (30 m) maximum with electrode cable capacitance of less than 30 pF/foot
Power Requirements .....	90-130 VAC, 50/60 Hz. (10 VA max.) or 180-260 VAC, 50/60 Hz. (10 VA max.)
Calibration Methods:	
2 POINT BUFFER.....	Automatic calibration and buffer recognition (for pH only) using two buffers from a selected buffer set*
<b>NOTE:</b> When using buffers that are not included in either analyzer buffer set, use only the "2 POINT SAMPLE" method for calibration.	

*\*Buffer Sets: 4.00, 7.00, and 10.00 pH; or  
DIN 19267 standard (1.09, 4.65, 6.79, 9.23, and 12.75 pH)*

1 POINT Buffer ..... Automatic calibration and buffer recognition  
(for pH only) using one buffer from a selected buffer set\*

**NOTE:** *When using a buffer that is not included in either analyzer buffer set, use only the "1 POINT SAMPLE" method for calibration.*

2 POINT SAMPLE. .... Enter two known sample values (determined  
(for pH only) by laboratory analysis or comparison reading) or two pH buffers

1 POINT SAMPLE ..... Enter one known sample value (determined  
(for pH or ORP) by laboratory analysis or comparison reading), or one known pH buffer value (or, for ORP measurement, one known reference solution value)

Analog Outputs ..... Two isolated 0/4-20 mA outputs; each with  
0.004 mA (12-bit) resolution and capability to drive up to 600 ohm loads

**NOTE:** *Each output can be assigned to represent the measured pH (or ORP) or temperature. Parameter values can be entered to define the endpoints at which the minimum and maximum mA output values are desired (range expand). During calibration, both outputs can be selected to hold their present values, transfer to preset values to operate control elements by an amount corresponding to those values, or remain active to respond to the measured value.*

Communication: RS-232 ..... Enables configuration and retrieval of measured data for one analyzer using IBM-compatible PC and optional GLI software tool kit

HART ..... Enables configuration and retrieval of measured data for multiple analyzers over a communication link using appropriate hand-held terminal or data system with HART software

Memory Backup (non-volatile) .... All user settings are retained indefinitely in memory (EEPROM)

EMI/RFI Conformance..... Exceeds U.S. and meets European standards for conducted and radiated emissions and immunity; certified CE compliant for applications as specified by EN 50081-1 for emissions and EN 50082-2 for immunity

Electrical Certifications:

General Purpose (pending) ..... CSA/CSA<sub>NRTL</sub> and FM (UL pending)  
Class I, Div. 2 (Groups A-D) ... CSA/CSA<sub>NRTL</sub> and FM (UL pending)

**2.2 Analyzer Performance  
(Electrical, Analog Outputs)**

Accuracy ..... 0.1% of span  
Stability ..... 0.05% of span per 24 hours, non-cumulative  
Repeatability ..... 0.1% of span or better  
Temperature Drift ..... Zero and Span: less than 0.03% of span/°C

**2.3 Mechanical**

Enclosure ..... NEMA 4X; polycarbonate face panel, epoxy-coated cast aluminum door and case with four 1/2 inch (13 mm) conduit holes, nylon mounting bracket, and stainless steel hardware

Mounting Configurations..... Panel, surface, and pipe (horizontal and vertical) mounting

Net Weight ..... 3.5 lbs. (1.6 kg) approximately

# PART TWO - INSTALLATION

## SECTION 1

### UNPACKING

After unpacking, it is recommended to save the shipping carton and packing materials in case the instrument must be stored or re-shipped. Inspect the equipment and packing materials for signs of shipping damage. If there is any evidence of damage, notify the transit carrier immediately.

## SECTION 2

### MECHANICAL REQUIREMENTS

#### 2.1 Location

1. It is recommended to locate the analyzer as close as possible to the installed sensor. Depending on the sensor type, the maximum allowable distance between the sensor and analyzer is:

GLI Differential Technique Sensor	Conventional Combination Electrode <b>with</b> preamp	Conventional Combination Electrode <b>without</b> preamp
3000 feet (914 m)	985 feet (300 m)	100 feet (30 m)

**Recommendation:** Directly connect the sensor to the analyzer to eliminate potential problems caused by wet environments when a junction box is used.

2. Mount the analyzer in a location that is:
  - Clean and dry where there is little or no vibration.
  - Protected from corrosive fluids.
  - Within ambient temperature limits (-4 to +140°F or -20 to +60°C).

**CAUTION:**

**EXPOSING THE ANALYZER TO DIRECT SUNLIGHT MAY INCREASE THE OPERATING TEMPERATURE ABOVE ITS SPECIFIED LIMIT, AND DECREASE DISPLAY VISIBILITY. RECOMMENDATION: IN SEVERE CASES, USE A GLI SUN SHIELD (P/N 1000G3088-001)**

**2.2 Mounting**

Figure 2-1 illustrates the various ways to mount the analyzer using the supplied bracket and hardware. Determine the mounting method and attach the hardware as shown in the respective illustration. Refer to Figure 2-2 for analyzer installation dimension details.

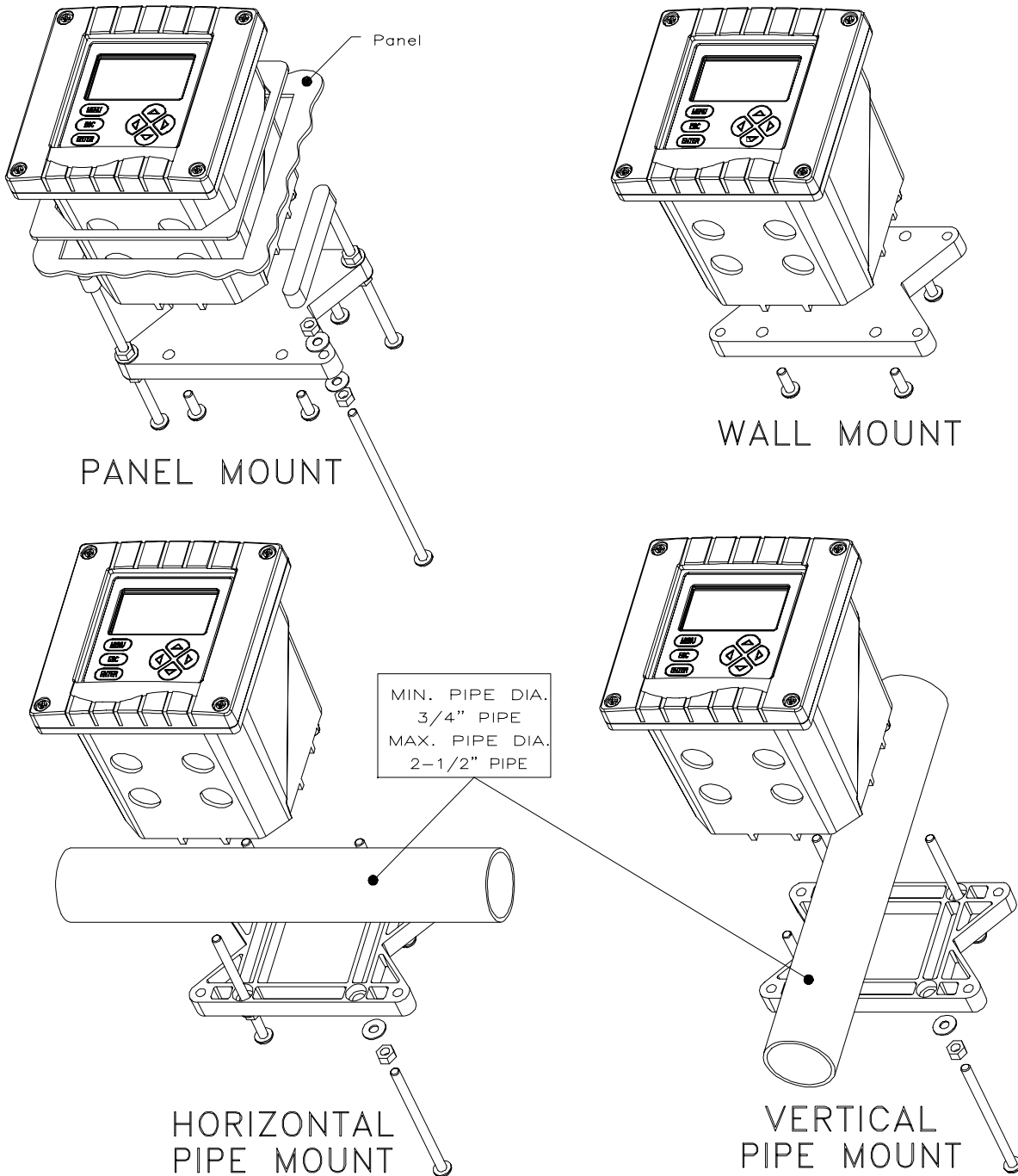

FIGURE 2-1 Analyzer Mounting Arrangements

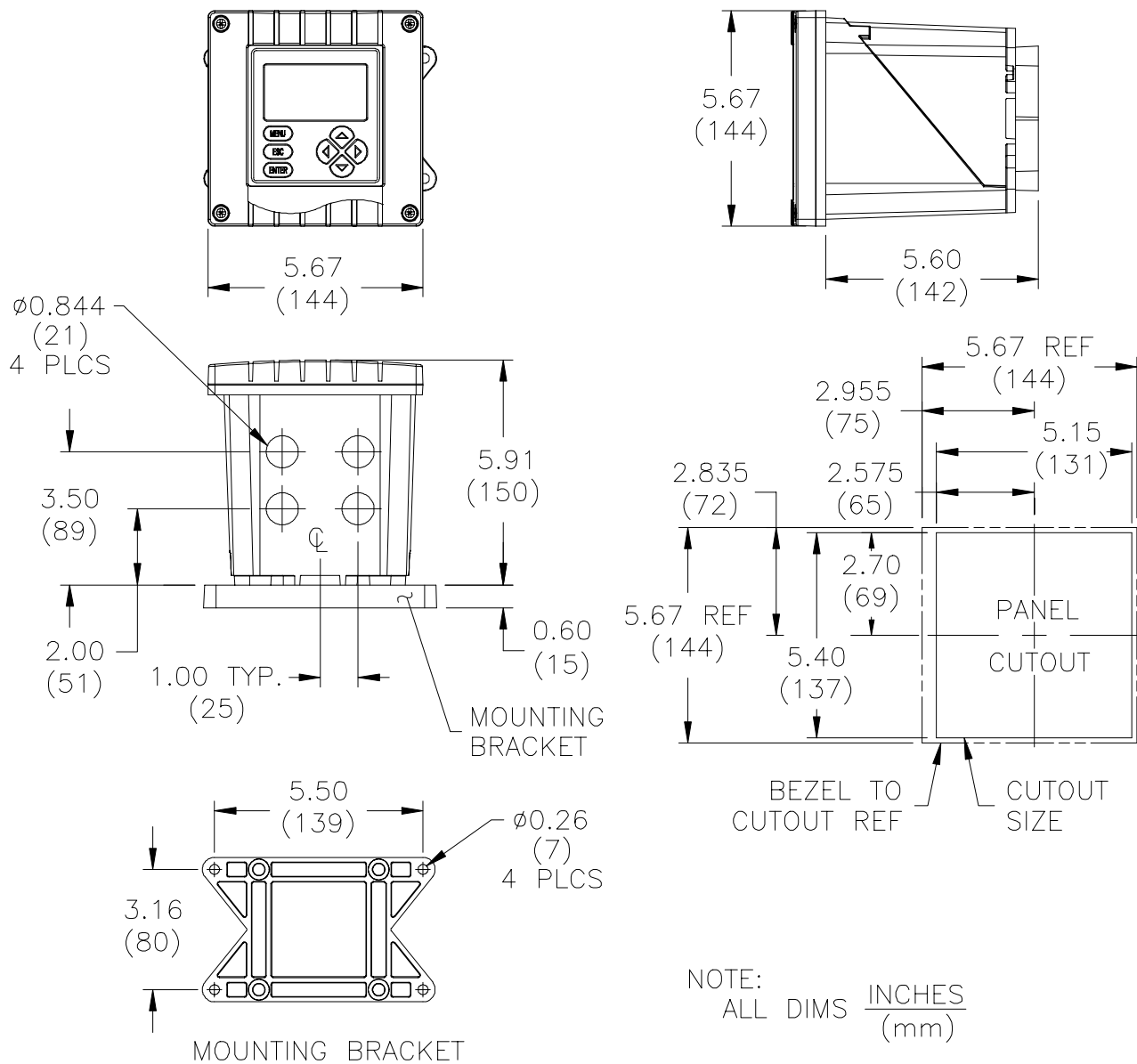

FIGURE 2-2 Analyzer Installation Dimensions Details

### 2.3 Conduit Hole Requirements

**Recommendation:** Run all wiring to the analyzer in 1/2-inch, grounded metal conduits. If using only shielded cables, appropriate strain reliefs or cable grips are required. (GLI offers accessory cable grips, part number 3H1091, and watertight locknuts, part number 3H1230, for cable entries.) Seal unused cable entry holes with appropriate plugs.



**NOTE:** Use NEMA 4-rated fittings and plugs to maintain the watertight integrity of the NEMA 4X enclosure.

## SECTION 3

## ELECTRICAL CONNECTIONS

To access terminals for electrical connections, open the left-hinged enclosure door by unscrewing the four fasteners. Figure 2-3 or 2-4 shows the terminal arrangement and their designations.



**NOTE:** All terminals are suitable for single wires up to 14 AWG (2.5 mm<sup>2</sup>). If the analyzer is equipped with only relays A and B, "RELAY C" and "RELAY D" terminals will not function (all relay designations are always shown).



**Wiring Tip!** To comply with European Community (CE) electromagnetic compatibility requirements, follow these general wiring guidelines:

1. Keep all cable shields as short as possible inside the analyzer, and connect them to the ground terminals provided. Performance may be improved by using cable glands that enable the shield to directly contact the analyzer chassis.
2. Use Steward ferrite 28 B0590-000 or equivalent on the sensor cable -- two turns required.
3. In harsh conducted RF conditions, connect the earth ground of the analyzer to a local, known earth ground source.



**NOTE:** For easier wiring, connect line power and relay outputs through the back conduit holes before connecting sensor and analog outputs through the front holes.

### 3.1 GLI Differential Technique Sensor

All GLI Differential Technique sensors have a built-in temperature element for automatic temperature compensation and for measuring process temperature.



**Wiring Tip!** Route the sensor cable in 1/2-inch, grounded metal conduit to protect it from moisture, electrical noise, and mechanical damage.

For installations where the distance between sensor and analyzer exceeds the sensor cable length, indirectly connect the sensor to the analyzer using a junction box and interconnect cable.



**NOTE:** Do not route the sensor cable in any conduit containing AC or DC power wiring (“electrical noise” may interfere with the sensor signal).

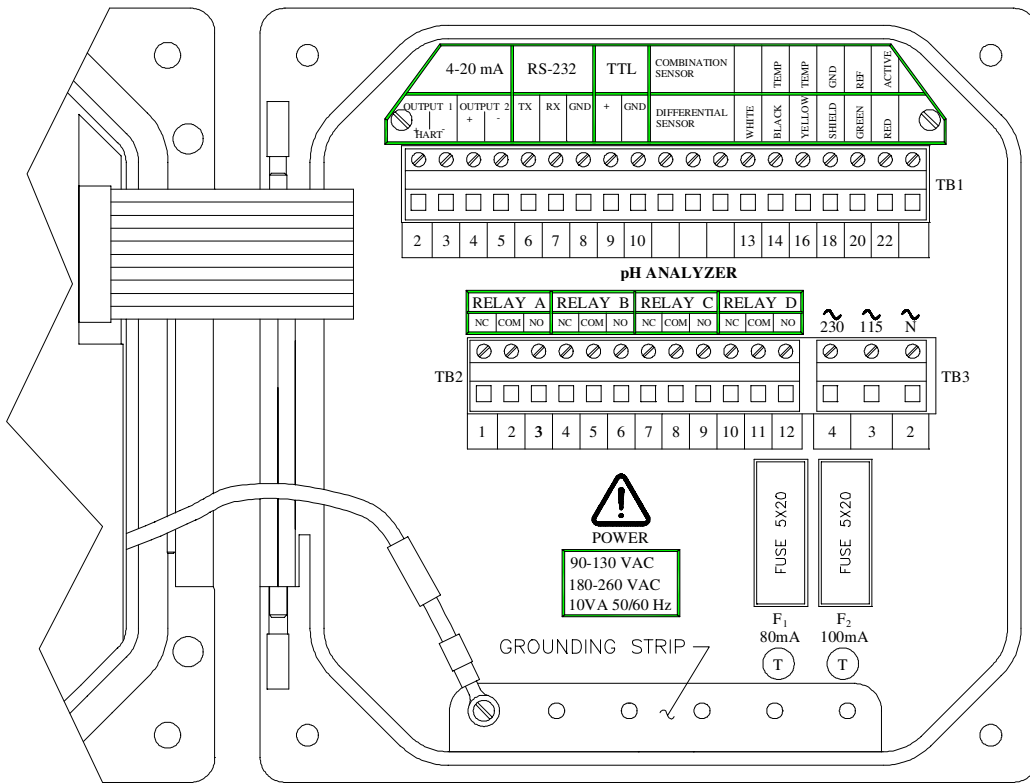

FIGURE 2-3 Terminal Designations for Analyzers with "B" Prefix Serial Number

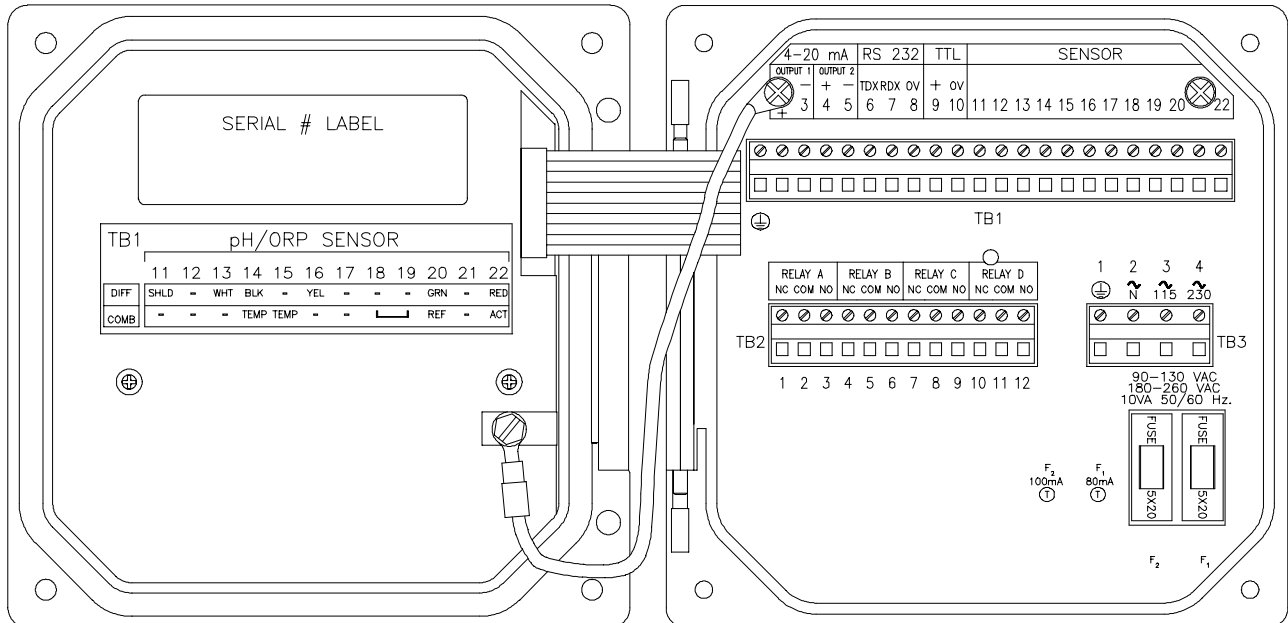

FIGURE 2-4 Terminal Designations for Analyzers with "A" or No Letter Prefix Serial Number

See Figure 2-5 or 2-6 and connect the sensor (or interconnect) cable wires to appropriate terminals on TB1, matching colors as indicated.



**NOTE:** For GLI Differential sensors that have two shield wires, always connect the outer shield to an earth ground terminal and the inner shield to the “shield” terminal.

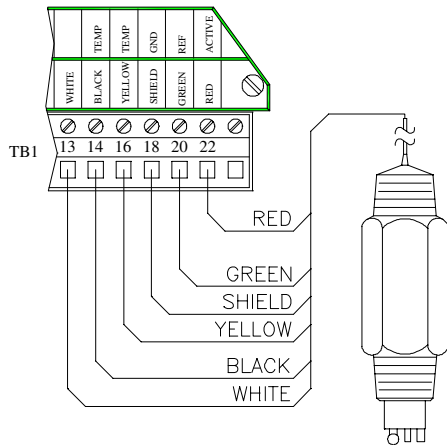

FIGURE 2-5 Connecting GLI Differential Technique Sensor to Analyzers with “B” Prefix Serial Number

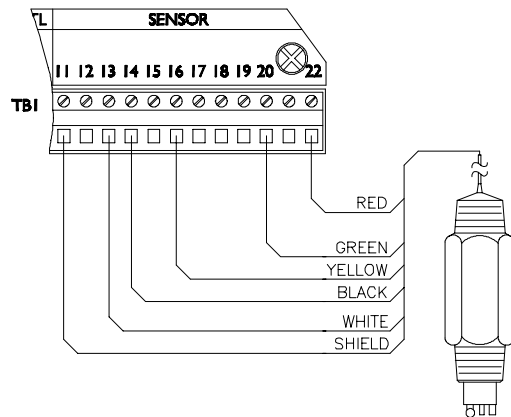

FIGURE 2-6 Connecting GLI Differential Technique Sensor to Analyzers with “A” or No Letter Prefix Serial Number

### 3.2 Conventional Combination Electrode

The electrode must be within 100 ft./30 m of analyzer (985 ft./300 m for electrode with preamp). See Figures 2-7 or 2-8 and directly connect electrode’s coaxial cable to analyzer.

1. Connect the electrode’s reference signal -- braided shield wire of coaxial cable (black insulated wire for GLI electrode) -- to Terminal 20 (REF) on TB1.
2. Connect the electrode’s active signal -- center wire of coaxial cable (clear insulated wire for GLI electrode) -- to Terminal 22 (ACTIVE) on TB1.

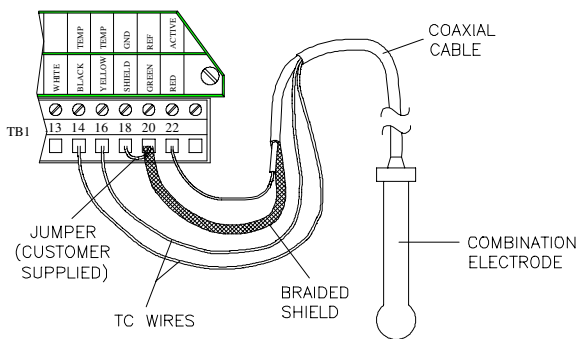

FIGURE 2-7 Connecting Conventional Combination Electrode to Analyzers with “B” Prefix Serial Number

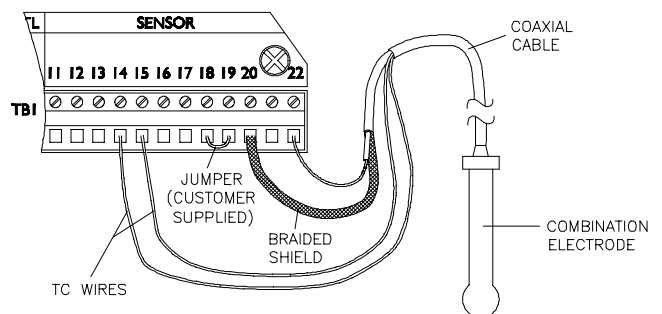

FIGURE 2-8 Connecting Conventional Combination Electrode to Analyzers with “A” or No Letter Prefix Serial Number

3. Connect a jumper between these TB1 terminals:
  - Terminals 18 and 20 for analyzers with “B” prefix serial number (Figure 2-7).
  - Terminals 18 and 19 for analyzers with “A” or no letter prefix serial number (Figure 2-8).
4. Connect the electrode’s temperature element (typically white and red insulated wires for GLI electrode) to these “TEMP” terminals on TB1:
  - Terminals 14 and 16 for analyzers with “B” prefix serial number, attaching either wire to either terminal (Figure 2-7).
  - Terminals 14 and 15 for analyzers with “A” or no letter prefix serial number (Figure 2-8).

### 3.3 Conventional Combination Electrode with Ground Rod

Some applications require that an external ground rod be used with the combination electrode. The electrode must be within 100 ft./30 m of the analyzer (985 ft./300 m for electrode with preamp). See Figure 2-9 or 2-10 and directly connect the electrode’s coaxial cable to the analyzer.

Connect the electrode and temperature element wires in the same way as described in Section 3.2 -- **except eliminate the jumper wire**. Instead, connect the ground rod wire to Terminal 18 on TB1.

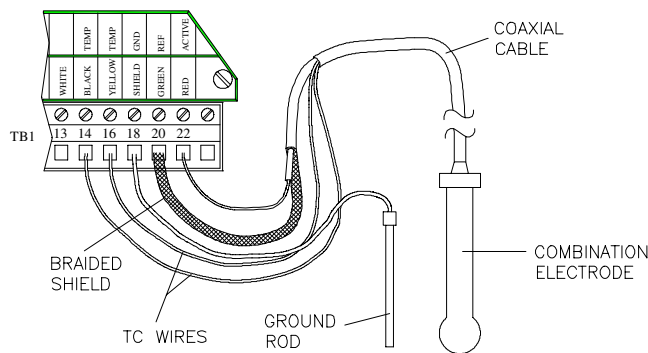

Figure 2-9 Connecting Conventional Combination Electrode with Ground Rod to Analyzers with “B” Prefix Serial Number

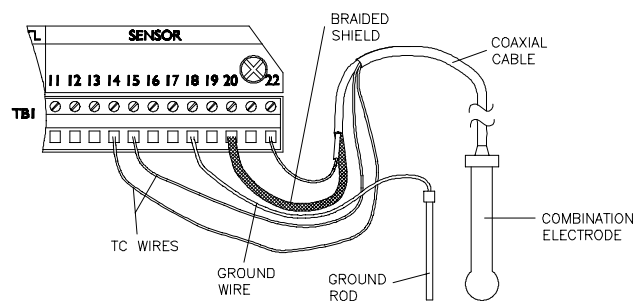

Figure 2-10 Connecting Conventional Combination Electrode with Ground Rod to Analyzers with “A” or No Letter Prefix Serial Number

### 3.4 Analog Outputs

Two isolated analog outputs (1 and 2) are provided. Each output can be set to be 0-20 mA or 4-20 mA, and assigned to represent the measured pH/ORP or temperature. **The outputs are isolated from the inputs and earth ground, but not from each other.** For output configuration details, see PART THREE, Section 4.4.



**Wiring Tip!** Use high quality, shielded instrumentation cable for connecting the analog outputs. To protect the output signals from EMI/RFI, connect cable shields to:

- The grounding strip at bottom of case (5 open holes, Fig. 2-3) for analyzers with “B” prefix serial number.
- The “ground symbol” Terminal 1 on TB1 (Figure 2-4) for analyzers with “A” or no letter prefix serial number.

Each 0/4-20 mA output can drive a load of up to 600 ohms.

- **Output 1:** Connect the load to Terminals 2 and 3 on TB1, matching polarity as indicated.
- **Output 2:** Connect the load to Terminals 4 and 5 on TB1, matching polarity as indicated.



**NOTE:** *When using the HART communication option, a digital signal is encoded onto the 4-20 mA analog Output 1 signal. In a HART point-to-point wiring configuration, Output 1 remains available for normal use. However, in a HART multi-drop wiring configuration, Output 1 becomes dedicated to that function and cannot be used. See PART THREE, Section 8 for more HART communication information.*

### 3.5 Relay Outputs

The analyzer may be equipped with up to four electromechanical relays. For relay setup details, see PART THREE, Section 4.5.

**CAUTION:**

**DO NOT EXCEED THE CONTACT RATING FOR EACH RELAY (5A 115/230 VAC). WHEN SWITCHING LARGER CURRENTS, USE AN AUXILIARY RELAY SWITCHED BY THE ANALYZER RELAY TO EXTEND ANALYZER RELAY LIFE. WHEN USING RELAY OUTPUTS, MAKE SURE THAT LINE POWER WIRING CAN ADEQUATELY CONDUCT THE CURRENT DRAW OF THE SWITCHED LOAD(S).**

Up to four sets of SPDT relay outputs (Relays A, B, C, and D) are provided at Terminals 1 through 12 on TB2. **The relay outputs are not powered.** The line power used to power the analyzer may also be used to power control/alarm devices with these relay contacts. See Figure 2-11 for a general wiring arrangement. Always check control wiring to insure that line power will not be shorted by the relay switching action, and that wiring conforms to local codes.

**WARNING:**

**MAKE SURE LINE POWER IS NOT PRESENT WHILE CONNECTING WIRES TO THE TB2 RELAY TERMINALS.**

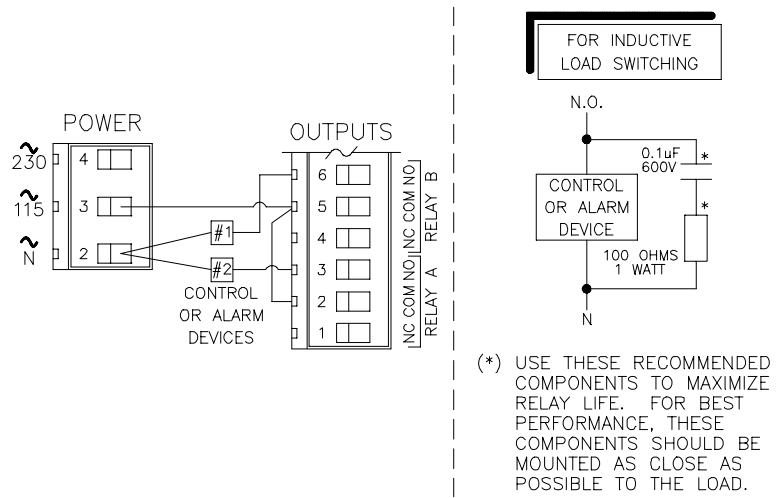

**FIGURE 2-11**  
*Connecting Control/Alarm Device(s) To Electromechanical Relay(s)*

### 3.6 Closed Contact TTL Input

The analyzer TTL input feature enables you to conveniently hold or transfer analog outputs and CONTROL and ALARM relays. How the TTL input feature functions depends on what output state (HOLD, XFER or ACTIVE) was selected during the last calibration:

- If HOLD was selected, the TTL input will hold analog outputs at their last measured values, and hold relays in their present “on/off” states.
- If XFER (transfer) was selected, the TTL input will transfer analog outputs to their user-entered preset values, and transfer relays to their user-entered preset “on/off” states.
- If ACTIVE was selected, the TTL input becomes disabled, keeping the outputs and relays active so they can respond to the measured value.

To apply a TTL hold or transfer, either locally or remotely connect TTL Terminal 9 to Terminal 10 on TB1. When this input is broken, the applied hold or transfer releases.



**NOTE:** *The TTL input feature can be affected by three other methods used to hold the analog outputs and relays, which are listed in order of precedence:*

1. **Selected Calibration Output State:** *The output state (HOLD, XFER or ACTIVE) selected during a calibration always takes precedence over the TTL input. If the TTL input was operating, it will be re-applied after calibration (or aborted calibration) and will function according to the last selected output state.*
2. **TEST/MAINT Menu HOLD OUTPUTS Function:** *The TEST/MAINT hold always takes precedence over the TTL input. If the TTL input was operating, it will be re-applied after the TEST/MAINT hold is released.*
3. **Active TIMER Relay:** *An applied TTL input always takes precedence over a TIMER relay. When the TTL input is applied, it suspends the TIMER relay countdown until the TTL input is released. Thereafter, the TIMER relay resumes its countdown from the point where it was suspended.*

### 3.7 Line Power

Refer to the following appropriate figures and connect line power to TB3 terminals using the standard three-wire connection arrangement. **Use wiring practices which conform to local codes** (example: National Electric Code Handbook in the U.S.A.).

**WARNING:**

**REMOVE LINE POWER WHILE CONNECTING LINE POWER WIRES TO THE TB3 TERMINALS. ALSO, USE ONLY THE STANDARD THREE-WIRE CONNECTION ARRANGEMENT FOR SINGLE-PHASE LINE POWER TO PREVENT AN UNSAFE CONDITION, AND TO ENSURE PROPER ANALYZER OPERATION.**



**NOTE:** *In all cases, connect the line power cable ground wire (usually green) to:*

- *The grounding strip at bottom of case (5 open holes -- Figures 2-12, 2-14 or 2-16) for analyzers with "B" prefix serial number.*
- *The "ground symbol" Terminal 1 on TB3 (Figures 2-13, 2-15 or 2-17) for analyzers with "A" or no letter prefix serial number.*

The "115" and "230" voltage circuits are protected with internal, board-mounted slow-blow fuses.



**NOTE:** *For 230 volt split phase line power, be sure to conform to local codes with regard to fusing the 115 volt line connected to the "N" terminal.*

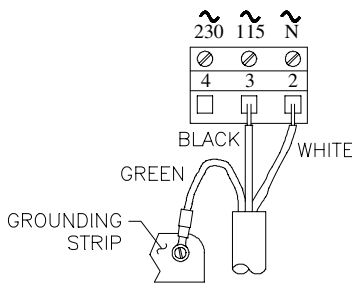

**FIGURE 2-12**  
Connecting 115 Volt Single Phase to Analyzers with "B" Prefix Serial Number

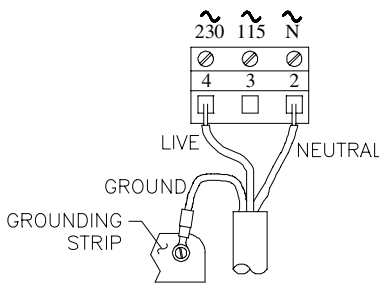

**FIGURE 2-13**  
Connecting 230 Volt Single Phase to Analyzers with "B" Prefix Serial Number

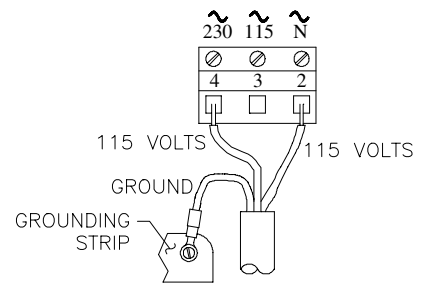

**FIGURE 2-14**  
Connecting 230 Volt Split Phase to Analyzers with "B" Prefix Serial Number

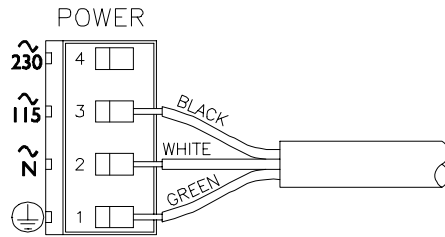

**FIGURE 2-15**  
*Connecting 115 Volt Single Phase  
to Analyzers with "A" or No Letter Prefix Serial Number*

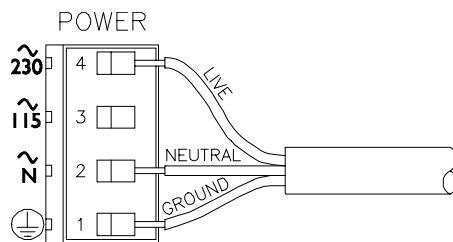

**FIGURE 2-16**  
*Connecting 230 Volt Single Phase  
to Analyzers with "A" or No Letter Prefix Serial Number*

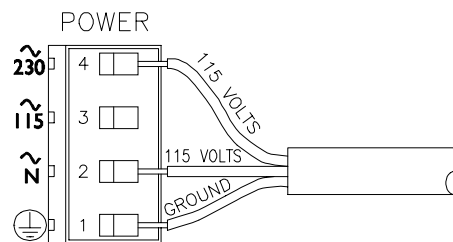

**FIGURE 2-17**  
*Connecting 230 Volt Split Phase  
to Analyzers with "A" or No Letter Prefix Serial Number*

# PART THREE - OPERATION

## SECTION 1

### USER INTERFACE

#### 1.1 Display

The user interface consists of an LCD display and a keypad with **MENU**, **ENTER**, **ESC**,  $\leftarrow$ ,  $\rightarrow$ ,  $\uparrow$ , and  $\downarrow$  keys.

By using the keypad, you can display three types of screens:

- **MEASURE Screen:** The normal display mode which shows measured values. The measured pH (or ORP) is always shown on the display's main middle line. Pressing the  $\downarrow$  or  $\uparrow$  key changes the display's bottom auxiliary line (in reverse video) to show these other measurements:
  - Measured temperature ( $^{\circ}\text{C}$  or  $^{\circ}\text{F}$ )
  - Analog Output 1 value (mA)
  - Analog Output 2 value (mA)

An example of a typical MEASURE screen is:

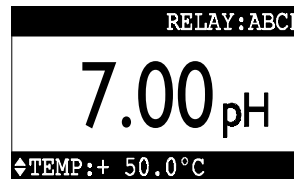

On the MEASURE screen's top line, Relay A, B, C, and D annunciators will appear when their relay operational state changes. When a relay overfeed timer is used and it has "timed out," the respective relay annunciator continuously blinks until the overfeed condition is resolved.

- **MENU Screens:** These top-level and lower-level (sub-menu) screens within the three main branches of the menu tree are used to access edit/selection screens for configuration. (EXIT screens at the end of each menu branch enable you to move up one level in the menu tree by pressing the **ENTER** key. This is functionally the same as pressing the **ESC** key.)
- **Edit/Selection Screens:** These screens enter values/choices to calibrate, configure, and test the analyzer.

#### 1.2 Keypad

The keypad enables you to move throughout the analyzer menu tree. The keys and their related functions are:

1. **MENU key:** Pressing this key always displays the top of the menu tree ("MAIN MENU" selection screen). To

display the top-level menu screen for a desired main branch (CALIBRATE, CONFIGURE or TEST/MAINT), use the **↓** and **↑** keys to select the corresponding line, and press the **ENTER** key. (Pressing the **MENU** key also “aborts” the procedure to change values or selections.

2. **ENTER** key: Pressing this key does two things: it displays submenu and edit/selection screens, and it enters (saves) configuration values/selections.
3. **ESC** key: Pressing this key always takes the display up one level in the menu tree. (Example: With the “MAIN MENU” branch selection screen displayed, pressing the **ESC** key once takes the display up one level to the MEASURE screen.) This key can also “abort” the procedure to change a value or selection.)
4. **↔** and **⇒** keys: Depending on the type of displayed screen, these keys do the following:
  - MEASURE/Menu Screens: These keys are non-functional.
  - Edit/Selection Screens: “Coarse” adjusts the displayed numerical value/choice.
5. **↑** and **↓** keys: Depending on the type of displayed screen, these keys do the following:
  - MEASURE Screen: Changes the bottom auxiliary display line, shown in reverse video, between measured temperature, and Output 1 or Output 2 mA value.
  - Menu Screens: Moves reverse video cursor up or down respectively to select a displayed line item.
  - Edit/Selection Screens: “Fine” adjusts numerical value, enclosed by parenthesis, up or down respectively or moves up or down respectively between choices enclosed by parenthesis.

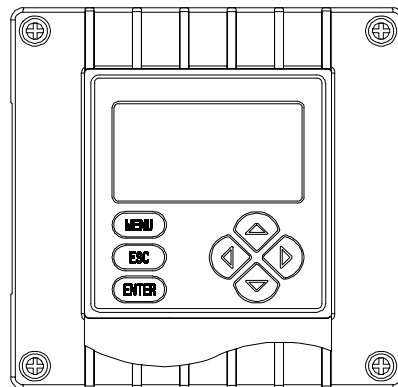
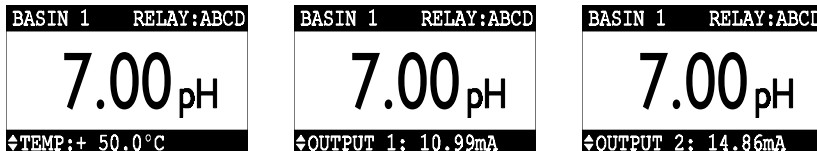

FIGURE 3-1 Analyzer Keypad

### 1.3 MEASURE Screen (normal display mode)

The MEASURE screen is normally displayed. Pressing the **MENU key** temporarily replaces the MEASURE screen with the “MAIN MENU” branch selection screen. Using the keypad, you can then display other screens to calibrate, configure or test the analyzer. **If the keypad is not used within 30 minutes, except during calibration and while using specific analyzer test/maintenance functions, the display will automatically return to the MEASURE screen.** To display the MEASURE screen at any time, press the **MENU key** once and then the **ESC key** once.

Pressing the ↓ or ↑ **key** with the MEASURE screen displayed scrolls between other measurements on the bottom auxiliary display line. These MEASURE screen examples illustrate this feature:



**NOTE:** *When the analyzer returns to its normal MEASURE screen mode, the appearing readout is always the version last selected.*

*Note that these MEASURE screen examples show “BASIN 1” notations on their top lines, illustrating the analyzer notation feature. To create your own notation, refer to PART THREE, Section 4.2, sub-heading “ENTER NOTE (top line of MEASURE screen).”*

*If pure water temperature compensation was selected (PART THREE, Section 4.2, subheading “Select Pure H2O COMP”) the MEASURE screen will show an asterisk after the pH reading to indicate it is being applied.*

When a measured value is beyond the analyzer measuring range, a series of “+” or “-” screen symbols appear, respectively indicating that the value is above or below range.

# SECTION 2

## MENU STRUCTURE

The analyzer menu tree is divided into three main branches: CALIBRATE, CONFIGURE, and TEST/MAINT. Each main branch is structured similarly in layers with top-level menu screens, related lower-level submenu screens and, in many cases, sub-submenu screens.

Each layer contains an EXIT line or screen to return the display up one level to the previous layer of screens.

**Menu Structure Tip!** For operating convenience, the layers within each main branch are organized with the most frequently used function screens at their beginning, rather than the functions used for initial startup.

### 2.1 Displaying Main Branch Selection Screen

Press the **MENU** key to always display this main branch selection screen:

```

MAIN MENU
▶CALIBRATE
▶CONFIGURE
▶TEST/MAINT
◀EXIT
    
```

### 2.2 Displaying Top-level Menu Screens

1. After displaying the main branch selection screen, use the **↓** and **↑** keys to select the line corresponding to the desired branch (shown in reverse video).
2. Press the **ENTER** key to display the top-level menu screen for that branch.

The top-level menu screens for each main branch are:

```

CALIBRATE
▶SENSOR
▶CAL OUTPUT
◀EXIT
    
```

```

CONFIGURE
▶SET OUTPUT 1
▶SET OUTPUT 2
▶SET RELAY A
▶SET RELAY B
▶SET RELAY C
▶SET RELAY D
▶SET PASSCODE
▶SET °C OR °F
▶LANGUAGE
▶SENSOR
◀EXIT
    
```

```

TEST/MAINT
▶STATUS
▶HOLD OUTPUTS
▶OVERFEED RESET
▶OUTPUT 1
▶OUTPUT 2
▶RELAY A
▶RELAY B
▶RELAY C
▶RELAY D
▶EPROM VERSION
▶SELECT SIM
▶SIM SENSOR
▶RESET CONFIG
▶RESET CAL
◀EXIT
    
```



**Menu Structure Tip!** The ▶ symbol pointing at each listed item indicates there is a related lower-level submenu screen, sub-submenu screen or edit/selection screen.

Some menu lists are too long to completely fit on the screen. A ↓ symbol at the bottom right of the list

indicates that you can display hidden items by pressing the **↓ key**. As you display these items a **↕** symbol appears, indicating that items now hidden above and below the list can be displayed by respectively pressing the **↑** or **↓ key**. When a **↑** symbol appears, it indicates you have reached the end of the menu list. You can move back up the list using the **↑ key**.



**NOTE:** The **▷** symbol pointing at a listed menu item indicates the item is not relevant to, nor required for, the previously entered setup choices, and is not available.

### 2.3 Displaying Submenu Screens

1. After displaying the top-level menu screen, use the **↓ and ↑ keys** to select the line corresponding to the desired lower-level submenu screen.
2. Press the **ENTER key** to display the submenu screen.

When a submenu or sub-submenu screen contains a first line ending with a “?”, it is an edit/selection screen. Pressing the **↓ or ↑ key** changes the value/choice enclosed by parenthesis (second line on screen).

**Example:** With this submenu edit screen displayed:

```
SET °C OR °F?
( °C )
```

pressing the **↓ key** displays this related choice:

```
SET °C OR °F?
( °F )
```

### 2.4 Adjusting Edit/Selection Screen Values

Using the **arrow keys** to edit/change the value/choice enclosed by parenthesis (examples shown above and below).

```
SET PARAMETER?
( SENSOR )
```

```
SET 4mA VALUE?
( 12.33 pH )
```

A choice can be changed by simply using the **↑ and ↓ keys**. Numerical values can be “coarse” adjusted using **⇐ and ⇒ keys**, and “fine” adjusted using **↑ and ↓ keys**. The longer the key is pressed, the faster the number changes.

### 2.5 Entering (Storing) Edit/Selection Screen Values/Choices

With the desired value/choice displayed, press the **ENTER key** to enter (store) it into the non-volatile analyzer memory. The previous screen will then re-appear.



**NOTE:** You can always press the **ESC key** to abort saving a new setting. The original setting will be retained.

## SECTION 3

## ADJUSTING DISPLAY CONTRAST

Ambient lighting conditions may make it necessary to adjust the analyzer display contrast to improve visibility. With the MEASURE screen displayed, press **and hold** the **ENTER** key and **simultaneously** press the **↑** or **↓** key until attaining the desired contrast.

## SECTION 4

## ANALYZER CONFIGURATION



**NOTE:** When the passcode feature is enabled (Section 4.6), you must successfully enter the passcode before attempting to enter a configuration setting.

#### 4.1 Selecting LANGUAGE to Operate Analyzer

The analyzer is equipped to display operating screens in various languages including English, French (Français), German (Deutsche), Spanish (Español), and others. The analyzer is factory-set for English. To change languages:

```

MAIN MENU
▶CALIBRATE
▶CONFIGURE
▶TEST/MAINT
◀EXIT
  
```

1. Press **MENU** key to display . Use **↓** key to select the "CONFIGURE" line.

```

CONFIGURE
▶SET OUTPUT 1
▶SET OUTPUT 2
▶SET RELAY A
▶SET RELAY B
▶SET RELAY C
▶SET RELAY D
▶SET PASSCODE
▶SET °C OR °F
▶LANGUAGE
▶SENSOR
◀EXIT
  
```

2. Press **ENTER** key to display . Use **↓** key to select the "LANGUAGE" line.

```

LANGUAGE?
(ENGLISH )
  
```

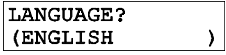
3. Press **ENTER** key to display . Use **↓** and **↑** keys to view the language choices. With the desired language displayed, press **ENTER** key to enter this selection.



**NOTE:** After a language is selected and entered, all screens will be displayed in that language.

## 4.2 Configuring Sensor Characteristics

The analyzer must be configured to define the sensor used with it, and other related items such as the display format, desired buffer set for calibration, temperature element, input signal filtering, pulse suppression, etc.

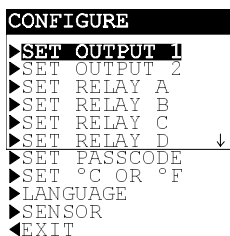

SELECT SENSOR Type

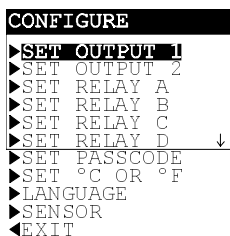
1. With the  screen displayed, use **↓** key to select the “SENSOR” line.

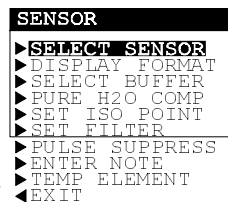

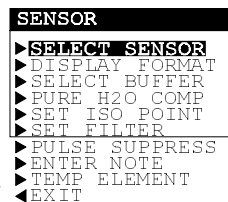
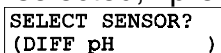
2. Press **ENTER** key to display .
3. With the “SELECT SENSOR” line selected, press **ENTER** key to display a screen like . Use **↓** and **↑** keys to view the four choices:

- **DIFF pH:** Configures analyzer to use a GLI 5-wire Differential pH sensor.
- **COMBINATION pH:** Configures analyzer to use a conventional combination pH electrode.
- **DIFF ORP:** Configures analyzer to use a GLI 5-wire Differential ORP sensor.
- **COMB ORP:** Configures analyzer to use a conventional combination ORP electrode.

**WARNING:**  
**CHANGING THE SENSOR TYPE AUTOMATICALLY REPLACES ALL USER-ENTERED VALUES WITH FACTORY-DEFAULT VALUES.**

4. With the desired choice displayed, press **ENTER** key to enter this selection.

## Select DISPLAY FORMAT

**When using the analyzer to measure ORP, this function is not provided.** (The ORP display format is fixed to show mV values as only whole numbers.) For pH measurement, choose the MEASURE screen display format to be XX.XX or XX.X. This format setting has no effect on edit/selection screens, which always show pH values in a XX.XX format.

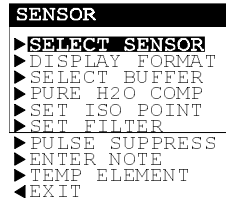

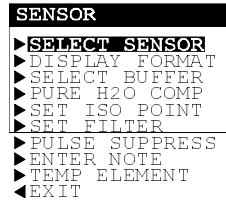
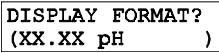
1. With the  screen displayed, use **↓ key** to select the “DISPLAY FORMAT” line.
2. Press **ENTER key** to display a screen like . Use **↓ and ↑ keys** to view both choices (XX.XX or XX.X). With the desired choice displayed, press **ENTER key** to enter this selection.

## SELECT BUFFER Set for pH Calibration

**When using the analyzer to measure ORP, this function is not provided.** For pH, configure the analyzer to use one of these buffer sets for pH calibration:

- 4.00, 7.00, and 10.00
- DIN 19267 standard (1.09, 4.65, 6.79, 9.23, and 12.75)



**NOTE:** When using buffers that are not included in either of the analyzer buffer sets, disregard selecting the buffer set. In this case, use only the “1 (or) 2 POINT SAMPLE” method for calibration.

The analyzer automatically recognizes pH values from the selected buffer set and uses its associated built-in table of pH-versus-temperature values to improve measurement accuracy. To select a buffer set:

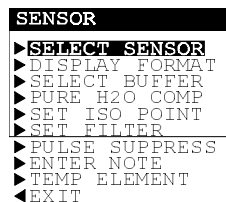

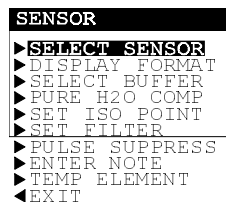
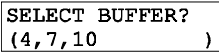
1. With the  screen displayed, use **↓ key** to select the “SELECT BUFFER” line.
2. Press **ENTER key** to display a screen like . Use **↓ and ↑ keys** to view both choices (4, 7, 10 or DIN 19267). With the desired choice displayed, press **ENTER key** to enter this selection.

Select PURE H2O COMP (only for special applications)



When using the analyzer to measure ORP, this function is not provided. When measuring pH in solutions with the weakly dissociating electrolytes ammonia or morpholine, built-in tables provide a correction factor for pure water temperature compensation. This special compensation is specifically for use in power plant applications. It adds an associated temperature-dependent offset, from the selected table, to the measured pH. If a custom compensation is required for pure water applications, a "user-defined" pH/°C linear slope factor can be applied to the measured pH.

**NOTE:** The selected pure water temperature compensation is limited to 50°C. If the process temperature is higher, the offset corresponding to 50°C is used.

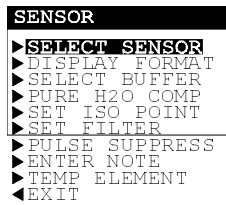

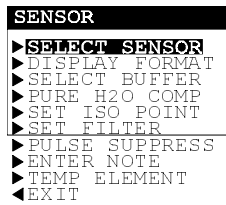
1. With the  screen displayed, use **↓ key** to select the "PURE H2O COMP" line.

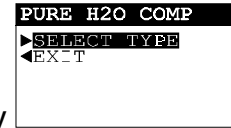

2. Press **ENTER key** to display .

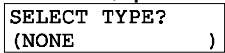
3. With the "SELECT TYPE" line selected, press **ENTER key** to display a screen like . Use **↓ and ↑ keys** to view the choices (NONE, AMMONIA, MORPHOLINE or USER DEFINED).

4. With the desired choice displayed, press **ENTER key** to enter this selection. When "USER DEFINED" is selected, you must set the specific pH/°C linear slope:

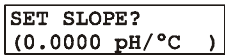

A. With the  screen displayed, use **↓ key** to select the "SET SLOPE" line.

B. Press **ENTER key** to display a screen like . Use **arrow keys** to adjust to adjust the displayed value to the desired slope, and press **ENTER key** to enter the value.



**NOTE:** The MEASURE screen will show an asterisk after the pH reading to indicate pure water temperature compensation was selected and is being applied.

SET ISO POINT  
(isopotential for special  
Differential pH sensor)



**This configuration setting only applies to GLI Differential pH sensors that contain a special “standard cell” buffer.** GLI Differential pH sensors normally contain 7.00 pH “standard cell” buffer, providing a theoretical output of zero mV at exactly 7.00 pH. This relationship is called the “isopotential.” A sensor with the normal 7.00 pH isopotential provides (-) 59.9 mV per pH at process values higher than 7.00 pH and (+) 59.9 mV per pH at process values lower than 7.00 pH. Special applications may require the sensor to have a special isopotential such as 6.50 pH. For best accuracy, set the analyzer to match the isopotential value of the special GLI Differential pH sensor.

**NOTE:** *Changing the isopotential setting always requires you to re-calibrate the analyzer. When using a conventional combination electrode, the isopotential value is irrelevant and does not apply.*

```

SENSOR
▶SELECT SENSOR
▶DISPLAY FORMAT
▶SELECT BUFFER
▶PURE H2O COMP
▶SET ISO POINT
▶SET FILTER
▶PULSE SUPPRESS
▶ENTER NOTE
▶TEMP ELEMENT
◀EXIT
  
```

1. With the screen displayed, use **↓ key** to select the “SET ISO POINT” line.
2. Press **ENTER key** to display a screen like 

```
SET ISO POINT?
(7.00 pH )
```

. Use **arrow keys** to adjust the displayed value to match the sensor’s isopotential, and press **ENTER key** to enter the value.

SET FILTER Time

A time constant (in seconds) can be set to filter or “smooth out” the sensor signal. A minimum value of “0 seconds” has no smoothing effect. A maximum value of “60 seconds” provides maximum smoothing. Deciding what sensor signal filter time to use is a compromise. The higher the filter time, the longer the sensor signal response time will be to a change in the actual process value.

```

SENSOR
▶SELECT SENSOR
▶DISPLAY FORMAT
▶SELECT BUFFER
▶PURE H2O COMP
▶SET ISO POINT
▶SET FILTER
▶PULSE SUPPRESS
▶ENTER NOTE
▶TEMP ELEMENT
◀EXIT
  
```

1. With the screen displayed, use **↓ key** to select the “SET FILTER” line.

2. Press **ENTER** key to display a screen like . Use **arrow keys** to adjust the displayed value to the desired filter time, and press **ENTER** key to enter the value.

Select  
PULSE SUPPRESS  
(on/off)

Sometimes an external interference may occasionally cause the measurement system to provide unstable readings. Common causes include entrained gas bubbles in the process, and electromagnetic interference (EMI or “electrical noise” pulses). The analyzer has a pulse suppression feature to counteract this condition and stabilize readings. Example: Suppose the analyzer reading is steadily showing 7.3 pH, then suddenly jumps to 9.8 pH for a few seconds, and returns to 7.3 pH. By turning on this feature, the analyzer will perceive this as a temporary upset, “suppressing” most of this pulse change and providing a smoother measurement reading.

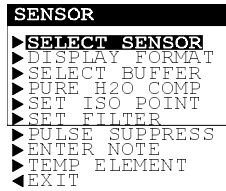

1. With the  screen displayed, use **↓ key** to select the “PULSE SUPPRESS” line.

2. Press **ENTER** key to display a screen like . Use **↓ and ↑ keys** to view both choices (OFF or ON). With the desired choice displayed, press **ENTER** key to enter this selection.

ENTER NOTE (top line  
of MEASURE screen)

The top line of the MEASURE screen is factory set to read “PH.” This notation can be changed, for example, to “BASIN 1” to tailor the analyzer MEASURE screen to the application. The top line would then be “MEASURE BASIN 1.” The notation is limited to eight characters which can be a combination of capital letters A through Z, numbers 0 through 9, and spaces.

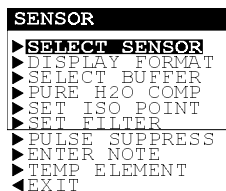

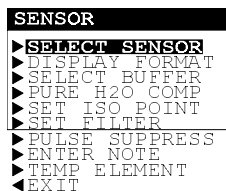
1. With the  screen displayed, use **↓ key** to select the “ENTER NOTE” line.

2. Press **ENTER** key to display 

ENTER NOTE? ([P]H )
------------------------

 . Create the desired notation on the second line:
  - A. Starting with extreme left character position, use **↑** and **↓** keys to select the desired first character.
  - B. Press **⇒** key once to select the next position, and use **↑** and **↓** keys to select its desired character.
  - C. Repeat this procedure until the desired notation is displayed.
3. Press **ENTER** key to enter the displayed notation.

Select TEMP ELEMENT Type

When measuring pH, configure the analyzer for either automatic temperature compensation (by defining the built-in or external temperature element) or fixed MANUAL temperature compensation. When using MANUAL you must determine and enter a specific temperature. **When using the analyzer to measure ORP, this function only defines the element used for temperature measurement. ORP measurement does not require temperature compensation and is unaffected by the measured temperature.**



**NOTE:** When a temperature element type has been selected but the element is not connected to the analyzer, a “WARNING: CHECK STATUS” message will appear. To prevent or clear this message, connect the element or select “MANUAL.”

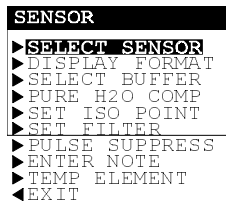

1. With the screen displayed, use **↓** key to select the “TEMP ELEMENT” line.

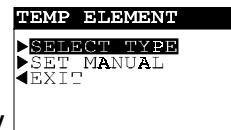

2. Press **ENTER** key to display
3. With the “SELECT TYPE” line selected, press **ENTER** key to display a screen like 

SELECT TYPE? (NTC 300 )
----------------------------

 . Use **↓** and **↑** keys to view the four choices:

- **NTC300:** Configures analyzer for use with an NTC 300 ohm thermistor temperature element (used in all GLI Differential pH and ORP sensors -- except Model 6006P4-2000 pure water pH sensor systems which use a Pt 1000 RTD).
- **PT1000:** Configures analyzer for use with a Pt 1000 RTD temperature element.
- **PT100:** Configures analyzer for use with a Pt 100 RTD temperature element.
- **MANUAL:** Configures analyzer for fixed manual temperature compensation -- for pH measurement only -- when not using a temperature element.

4. With desired choice displayed, press **ENTER** key to enter this selection. When “MANUAL” is selected, you must set the specific manual temperature compensation value:

```

TEMP ELEMENT
▶SELECT TYPE
▶SET MANUAL
◀EXIT
  
```

- A. With the screen displayed, use **↓** key to select the “SET MANUAL” line.
- B. Press **ENTER** key to display a screen like 

```
SET MANUAL?
(25.0°C )
```

. Use **arrow keys** to adjust the displayed value to the desired fixed temperature, and press **ENTER** key to enter it.

### 4.3 Set °C OR °F (temperature display format)

The MEASURE screen can be set to display temperature values in °C or °F. In either case, the temperature display format is always “XX.X.”

```

TEMP ELEMENT
▶SELECT TYPE
▶SET MANUAL
◀EXIT
  
```

1. With the sub-submenu screen displayed,

```

CONFIGURE
▶SET OUTPUT 1
▶SET OUTPUT 2
▶SET RELAY A
▶SET RELAY B
▶SET RELAY C
▶SET RELAY D
▶SET PASSCODE
▶SET °C OR °F
▶LANGUAGE
▶SENSOR
◀EXIT
  
```

press **ESC** key twice to display

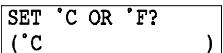
2. Use **↓ key** to select the “SET °C OR °F” line.
3. Press **ENTER key** to display a screen like . Use **↓ and ↑ keys** to view both choices (°C or °F). With the desired choice displayed, press **ENTER key** to enter this selection.

#### 4.4 Configuring Analog Outputs (1 and 2)

The analyzer provides two isolated analog outputs (1 and 2). During calibration, the analog outputs can be held, transferred to a preset mA value or remain active. During normal measurement operation, both analog outputs can be held at their last measured values:

- For up to 30 minutes by selecting the “HOLD OUTPUTS” line in the TEST/MAINT menu and pressing the **ENTER key**.
- For an indefinite period by locally or remotely connecting the TTL input Terminals 9 and 10 on TB1.
- By an activated TIMER relay for its entered DURATION and OFF DELAY time periods (1-999 seconds each)

The output state (HOLD, XFER or ACTIVE) selected during calibration always takes precedence over an applied TTL input hold/transfer and/or TIMER relay hold. For more details on order of precedence for hold functions, refer to PART TWO, Section 3.6.

From the moment output hold is initiated (during calibration, from TEST/MAINT menu or by TTL input), the elapsed time INTERVAL or DURATION countdown for a TIMER relay is temporarily suspended. Also, any TIMER relay counting down DURATION time is turned off. When output hold is released, a TIMER relay resumes its INTERVAL or DURATION countdown from the suspended time. When a TIMER relay is counting down DURATION time, both outputs are temporarily held until after the preset DURATION time (and OFF TIME, if used) elapses.



**NOTE:** When using the HART communication option, a digital signal is encoded onto the 4-20 mA analog Output 1 signal. In a HART SINGLE MODE wiring configuration, Output 1 remains available for normal use. However, in a HART MULTI-DROP wiring con-

figuration, Output 1 becomes dedicated to that function and cannot be used. See PART THREE, Section 8 for more HART communication information.

**These instructions configure Output 1. Configure Output 2 in the same way using its respective menu screens.**

SET PARAMETER  
(representation)

Each output can be assigned to represent the SENSOR (measured pH or ORP) or measured TEMPERATURE.

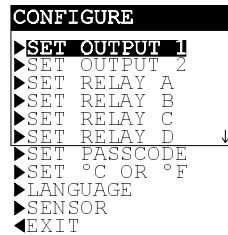

1. With the screen displayed and the "SET OUTPUT 1" line selected, press **ENTER** key to

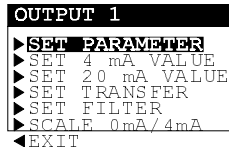

display

2. With the "SET PARAMETER" line selected, press **ENTER** key to display a screen like 

SET PARAMETER? (SENSOR )
-----------------------------

. Use **↓** and **↑** keys to view both choices (SENSOR or TEMPERATURE). With the desired choice displayed, press **ENTER** key to enter this selection.

SET 0/4 mA and  
20 mA VALUES  
(range expand)

Parameter values can be set to define the endpoints at which the minimum and maximum analog output values are desired.

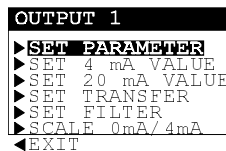

1. With the screen displayed, use **↓** key to select the "SET 4 mA VALUE" line.

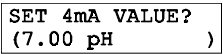
- Press **ENTER** key to display a screen like . Use **arrow keys** to set the displayed value at which 0/4 mA is desired, and press **ENTER** key to enter the value.

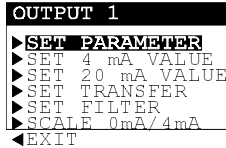

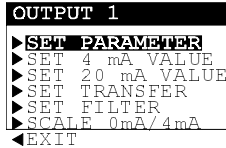
- After the  screen re-appears, use **↓ key** to select the “SET 20 mA VALUE” line.

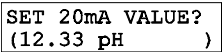
- Press **ENTER** key to display a screen like . Use **arrow keys** to set the displayed value at which 20 mA is desired, and press **ENTER** key to enter the value.



**NOTE:** If the same values are set for 0/4 mA and 20 mA, the output automatically goes to, and remains at, 20 mA.

SET TRANSFER  
Value (mA)

Each analog output is normally active, responding to the measured value of its assigned parameter. However, during calibration, you can transfer (XFER) each output to a preset value to operate a control element by an amount corresponding to that value.

To set a mA transfer value for an analog output to suit your application:

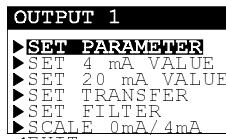

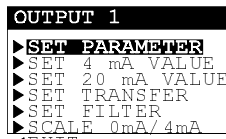

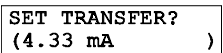
- With the  screen displayed, use **↓ key** to select the “SET TRANSFER” line.

- Press **ENTER** key to display a screen like . Use **arrow keys** to set the displayed value to the desired mA transfer value, and press **ENTER** key to enter the value.

SET FILTER Time

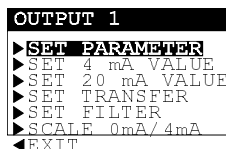
A time constant (in seconds) can be set to filter or “smooth out” the output signal. A minimum value of “0 seconds” has no smoothing effect. A maximum value of “60 seconds” provides maximum smoothing. Deciding what output filter time to use is a compromise. The higher the filter time, the longer the output signal response time will be to a change in the measured value.

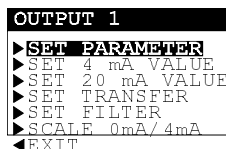

1. With the  screen displayed, use **↓ key** to select the “SET FILTER” line.
2. Press **ENTER key** to display a screen like . Use **arrow keys** to adjust the displayed value to the desired filter time, and press **ENTER key** to enter it.

Select SCALE 0 mA/ 4 mA (low endpoint)

Each output can be set to be 0-20 mA or 4-20 mA.

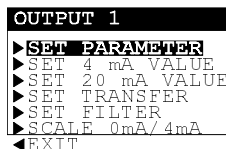

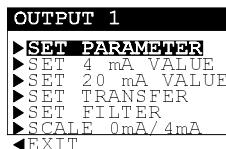
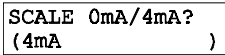
1. With the  screen displayed, use **↓ key** to select the “SCALE 0mA/4mA” line.
2. Press **ENTER key** to display a screen like . Use **↓ and ↑ keys** to view both choices. With the desired choice displayed, press **ENTER key** to enter this selection.

### 4.5 Configuring Relays (A, B, C, and D)

The analyzer may be equipped with up to four electromechanical relays (A, B, C, and D). Each relay can be set to function as a CONTROL, ALARM, STATUS or TIMER relay. For details on each relay function, see subsection "SET FUNCTION Mode."

During calibration, CONTROL and ALARM relays can be held, transferred to preset on/off states or remain active. During normal measurement operation, CONTROL and ALARM relays can be held at their present on/off states:

- For up to 30 minutes by selecting the "HOLD OUTPUTS" line in the TEST/MAINT menu and pressing the **ENTER** key.
- For an indefinite period by locally or remotely connecting the TTL input Terminals 9 and 10 on TB1.

The output state (HOLD, XFER or ACTIVE) selected during calibration always takes precedence over an applied TTL input hold/transfer. For more details on order of precedence for hold functions, refer to PART TWO, Section 3.6.



**NOTE:** *TIMER relays operate differently than CONTROL or ALARM relays, and are affected differently. See the TIMER relay description in the "SET FUNCTION Mode" subsection for details.*

**These instructions configure Relay A. Configure other relays in the same way using their respective menu screens.**

SET PARAMETER  
(representation)

Each CONTROL or ALARM relay can be assigned to be driven by the SENSOR (measured pH or ORP) or measured TEMPERATURE.

```

OUTPUT 1
▶SET PARAMETER
▶SET 4 mA VALUE
▶SET 20 mA VALUE
▶SET TRANSFER
▶SET FILTER
▶SCALE 0mA/4mA
◀EXIT

```

1. With the submenu screen displayed,

```

CONFIGURE
▶SET OUTPUT 1
▶SET OUTPUT 2
▶SET RELAY A
▶SET RELAY B
▶SET RELAY C
▶SET RELAY D
▶SET PASSCODE
▶SET °C OR °F
▶LANGUAGE
▶SENSOR
◀EXIT

```

press **ESC** key once to display

2. Use  $\downarrow$  **key** to select the “SET RELAY A” line, and press

```

RELAY A
▶SET PARAMETER
▶SET FUNCTION
▶SET TRANSFER
▶ACTIVATION
◀EXIT
  
```

**ENTER key** to display

3. With the “SET PARAMETER” line selected, press

```

SET PARAMETER?
(SENSOR      )
  
```

**ENTER key** to display a screen like

Use  $\downarrow$  **and**  $\uparrow$  **keys** to view both choices (SENSOR or TEMPERATURE). With the desired choice displayed, press **ENTER key** to enter this selection.

SET FUNCTION Mode  
(alarm, control,  
status or timer)

Each relay can be selected to function as a:



- **ALARM** relay (with separate high and low alarm points and deadbands) that operates in response to the measured pH (or ORP) or temperature.
- **CONTROL** relay (with phasing, setpoint, deadband, and overfeed timer) that operates in response to the measured pH (or ORP) or temperature.
- **STATUS** relay that is not configurable. It is a dedicated system diagnostic-only alarm relay that automatically energizes when the “WARNING CHECK STATUS” message flashes on the MEASURE screen. This occurs when the analyzer detects a sensor or analyzer “fail” diagnostic condition (see PART THREE, Section 6.1 for details).
- **TIMER** relay that is intended to control a GLI sensor cleaning system (or equivalent) on a timed basis. A TIMER relay activates after an entered INTERVAL time (up to 999.9 minutes) expires. The TIMER relay remains on for the entered DURATION time (1-999 seconds).

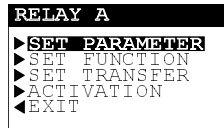

**NOTE:** When a **TIMER** relay is counting down **DURATION** time, both analog outputs and all **ALARM** and **CONTROL** relays are automatically “held” to ensure that connected devices are not disrupted by the sensor cleaning upset condition. An **OFF DELAY** time (1-999 seconds) can be entered to define how long after the **TIMER** relay turns off that outputs and relays will remain held, providing time for the sensor to stabilize after cleaning.

From the moment output hold is initiated (during calibration, from TEST/MAINT menu or by TTL input), the elapsed time INTERVAL or DURATION countdown for a TIMER relay is temporarily suspended. Also, any TIMER relay counting down DURATION time is turned off. When output hold is released, a TIMER relay resumes its INTERVAL or DURATION countdown from the suspended time. When a TIMER relay is counting down DURATION time, both outputs are temporarily held until after the preset DURATION time (and OFF TIME, if used) elapses.

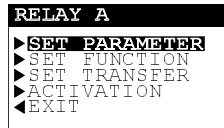



1. With the  screen displayed, use **↓ key** to select the “SET FUNCTION” line.
2. Press **ENTER key** to display a screen like . Use **↓ and ↑ keys** to view the choices (ALARM, CONTROL, STATUS or TIMER). With the desired choice displayed, press **ENTER key** to enter this selection.

SET TRANSFER Mode  
(relay on or off)

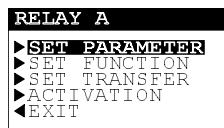
Normally, each CONTROL and ALARM relay is active, responding to the measured value of its assigned parameter (pH or ORP, or temperature). During calibration, however, you can transfer (XFER) each relay to a preset on/off transfer state to suit your application requirements:

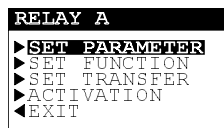

1. With the  screen displayed, use **↓ key** to select the “SET TRANSFER” line.
2. Press **ENTER key** to display a screen like . Use **↓ and ↑ keys** to view both choices (DE-ENERGIZED or ENERGIZED). With the desired choice displayed, press **ENTER key** to enter this selection.

ACTIVATION  
(configuration values)

The group of configuration settings available to a relay is dependent on its selected function mode (ALARM, CONTROL or TIMER). **Relays set for STATUS function are not configurable.** Table A describes all relay configuration settings, categorized by relay function mode:

Table A -- RELAY CONFIGURATION SETTINGS	
Setting	Description
For ALARM Relay	
Low Alarm	Sets the value at which the relay will turn on in response to <u>decreasing</u> measured value.
High Alarm	Sets the value at which the relay will turn on in response to <u>increasing</u> measured value.
Low Deadband	Sets the range in which the relay remains on after the measured value <u>increases above</u> the low alarm value.
High Deadband	Sets the range in which the relay remains on after the measured value <u>decreases below</u> the high alarm value.
Off Delay	Sets a time (0-300 seconds) to delay the relay from normally turning <u>off</u> .
On Delay	Sets a time (0-300 seconds) to delay the relay from normally turning <u>on</u> .
For CONTROL Relay	
Phase	A "high" phase assigns the relay setpoint to respond to increasing measured value; conversely, a "low" phase assigns the relay setpoint to respond to decreasing measured value.
Setpoint	Sets the value at which the relay will turn on.
Deadband	Sets the range in which the relay remains on after the measured value decreases below the setpoint value (high phase relay) or increases above the setpoint value (low phase relay).
Overfeed Timer	Sets the time (0-999.9 min.) to limit how long the relay can remain "on." For more details on overfeed timer operation, see Part Three, Section 7.
Off Delay	Sets a time (0-300 seconds) to delay the relay from normally turning <u>off</u> .
On Delay	Sets a time (0-300 seconds) to delay the relay from normally turning <u>on</u> .
For TIMER Relay	
Interval	Sets a time (0-999.9 min.) to establish how long the relay remains "off" before it starts a sensor cleaning.
Duration	Sets the time (0-999 seconds) to limit how long the timer relay remains "on" (sensor cleaning duration).
Off Delay	Sets a time (0-999 seconds) to establish how long after the timer relay turns off that the analog outputs and alarm and control relays remain "held."
For STATUS Relay	
No settings available -- status relay cannot be configured.	



**NOTE:** It is possible to enter values that always keep a relay active or inactive. To avoid this, be sure that “low” values are lower than “high” values.

When a relay is set for STATUS function, the ▷ symbol at the start of the “ACTIVATION” line denotes that this menu item is not available.

The “off delay” and “on delay” settings, available to CONTROL or ALARM function relays, may be beneficial in eliminating process “overshoot” when there are long process pipe runs or delays in mixing.

To set relay configuration values (ACTIVATION):

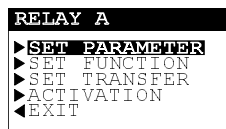

1. With the screen displayed, use ↓ key to select the “ACTIVATION” line.
2. Depending on the selected relay function, pressing ENTER key displays:

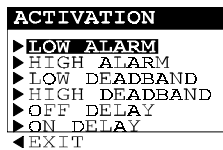

when ALARM mode is selected.

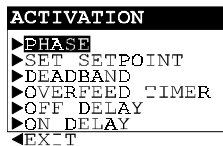

when CONTROL mode is selected.



when TIMER mode is selected.

3. Use ↓ key to select the appropriate relay setting line, and press ENTER key to display its corresponding edit/selection screen.
4. Use the same basic keypad operations described in previous setup procedures to enter the desired value for the displayed relay activation setting.
5. Repeat this procedure for each relay activation setting.

#### 4.6 SET PASSCODE (feature enabled or disabled)

The analyzer has a passcode feature to restrict access to configuration and calibration settings to only authorized personnel.

- **DISABLED:** With passcode feature disabled, all configuration settings can be displayed and changed, and the analyzer can be calibrated.
- **ENABLED:** With passcode feature enabled, all configuration settings can be displayed -- but they cannot be changed, and the CALIBRATE and TEST/MAINT menus cannot be accessed without the passcode. When you attempt to change a setting in the CONFIGURE menu by pressing the **ENTER** key, a displayed notification requests passcode entry. A valid passcode entry saves the changed setting and returns the display to the “MAIN MENU” branch selection screen. An incorrect passcode entry causes the display to momentarily show an error notification before returning to the “MAIN MENU” branch selection screen. There is no limit on attempts to enter a valid passcode.

The passcode is factory-set to “3456.” It cannot be changed.

To enable or disable the passcode feature:

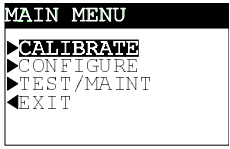
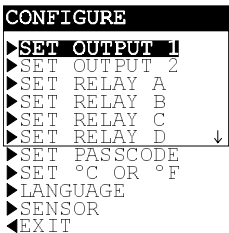
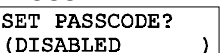
1. Press **MENU** key to display . Use **↓** key to select the “CONFIGURE” line.
2. Press **ENTER** key to display . Use **↓** key to select the “SET PASSCODE” line.
3. Press **ENTER** key to display a screen like . Use **↓** and **↑** keys to view both choices (DISABLED or ENABLED). With the desired choice displayed, press **ENTER** key to enter this selection.

#### 4.7 Configuration Setting Summary

Table B lists all configuration settings and their entry ranges/choices and factory defaults, categorized by basic functions.

Table B -- ANALYZER CONFIGURATION SETTINGS (RANGES/CHOICES and DEFAULTS)			
Displayed Screen Title	Entry Range or Choices (where applicable)	Factory Default	Your Setting
<b>LANGUAGE Setting</b>			
LANGUAGE?	ENGLISH, FRENCH, GERMAN, SPANISH, etc.	ENGLISH	
<b>SENSOR Settings</b>			
SELECT SENSOR?	DIFF pH, COMBINATION pH, DIFF ORP or COMB ORP	DIFF pH	
DISPLAY FORMAT?	XX.XX pH or XX.X pH	XX.XX pH	
SELECT BUFFER?	"4, 7, 10" or DIN 19267	"4, 7, 10"	
PURE H2O COMP SELECT TYPE?	NONE, AMMONIA, MORPHOLINE or USER DEFINED	NONE	
SET ISO POINT?	2.00-10.00 pH	7.00 pH	
SET FILTER?	0-60 seconds	0 seconds	
PULSE SUPPRESS?	OFF or ON	OFF	
ENTER NOTE?	Enter up to eight characters to replace PH	PH	
TEMP ELE:SELECT TYPE?	NTC300, PT1000, PT100 or MANUAL	NTC300	
TEMP ELE:SET MANUAL?	0.0-100.0°C	25.0°C	
<b>TEMPERATURE Display Setting</b>			
SET °C OR °F?	°C or °F	°C	
<b>OUTPUT Settings</b>			
SET PARAMETER?	SENSOR or TEMPERATURE	Output 1: SENSOR Output 2: TEMPERATURE	
SET 4mA VALUE?	pH: -2.00 to +14.00 pH ORP: -2100 to +2100 mV TEMP: -20.0 to +200.0°C or -4.0 to 392.0°F	pH: 0.00 pH ORP: 0 mV TEMP: 0.0°C or 32.0°F	
SET 20mA VALUE?	pH: -2.00 to +14.00 pH ORP: -2100 to +2100 mV TEMP: -20.0 to +200.0°C or -4.0 to 392.0°F	pH: 14.00 pH ORP: +2100 mV TEMP: 200.0°C or 392.0°F	
SET TRANSFER?	0-20 mA or 4-20 mA	All Outputs: 12 mA	
SET FILTER?	0-60 seconds	All Outputs: 0 seconds	
SCALE 0mA/4mA?	0 mA or 4 mA	All Outputs: 4 mA	
<b>RELAY Settings</b>			
Settings Common To ALARM and CONTROL Relays:			
SET PARAMETER?	SENSOR or TEMPERATURE	Relay A: SENSOR Relay B: TEMPERATURE	

(Table B continued on next page.)

<b>Table B -- ANALYZER CONFIGURATION SETTINGS (RANGES/CHOICES and DEFAULTS -- continued)</b>			
Displayed Screen Title	Entry Range or Choices (where applicable)	Factory Default	Your Setting
Settings Common To ALARM and CONTROL Relays (continued):			
SET FUNCTION?	ALARM, CONTROL, STATUS or TIMER	All Relays: ALARM	
SET TRANSFER?	DE-ENERGIZED or ENERGIZED	All Relays: DE-ENERGIZED	
OFF DELAY?	0-300 seconds	0 seconds	
ON DELAY?	0-300 seconds	0 seconds	
Settings for only ALARM Relays:			
LOW ALARM?	pH: -2.00 to +14.00 pH ORP: -2100 to +2100 mV TEMP: -20.0 to +200.0°C or -4.0 to 392.0°F	pH: 0.00 pH ORP: 0 mV TEMP: 0.0°C or 32.0°F	
HIGH ALARM?	pH: -2.00 to +14.00 pH ORP: -2100 to +2100 mV TEMP: -20.0 to +200.0°C or -4.0 to 392.0°F	pH: 14.00 pH ORP: +2000 mV TEMP: 200.0°C or 392.0°F	
LOW DEADBAND?	pH: 0-10% of range ORP: 0-10% of range TEMP: 0-10% of range	pH: 0.00 pH ORP: 0 mV TEMP: 0.0°C/°F	
HIGH DEADBAND?	pH: 0-10% of range ORP: 0-10% of range TEMP: 0-10% of range	pH: 0.00 pH ORP: 0 mV Temp: 0.0°C/°F	
Settings for only CONTROL Relays:			
PHASE?	HIGH or LOW	All Relays: HIGH	
SET SETPOINT?	pH: -2.00 to +14.00 pH ORP: -2100 to +2100 mV TEMP: -20.0 to +200.0°C or -4.0 to 392.0°F	pH: 14.00 pH ORP: +2000 mV TEMP: 200.0°C or 392.0°F	
DEADBAND?	pH: 0-10% of range ORP: 0-10% of range TEMP: 0-10% of range	pH: 0.00 pH ORP: 0 mV TEMP: 0.0°C/°F	
OVERFEED TIMER?	0-999.9 minutes	0 minutes	
Settings for only TIMER Relays:			
INTERVAL?	0-999.9 minutes	5 minutes	
DURATION?	0-999 seconds	5 seconds	
OFF DELAY?	0-999 seconds	1 second	
<b>PASSCODE Setting</b>			
SET PASSCODE?	DISABLED or ENABLED	DISABLED	
<b>TEST/MAINT Simulation Function Settings</b>			
SELECT SIM?	SENSOR or TEMPERATURE	SENSOR	
SIM SENSOR?	pH: -2.00 to +14.00 pH ORP: -2100 to +2100 mV TEMP: -20.0 to +200.0°C or -4.0 to 392.0°F	Present measured value of sensor's selected parameter (pH, ORP or temperature)	

## SECTION 5

## ANALYZER CALIBRATION

## 5.1 Important Information

## Calibrate Periodically

Four methods are available for pH calibration (Section 5.2). To calibrate ORP, use only the 1-POINT SAMPLE method described in Section 5.3. The mA value for each analog output can also be calibrated (Section 5.4).

To maintain best measurement accuracy, periodically calibrate the analyzer. Performance of the pH or ORP sensor slowly degrades over time, eventually causing inaccurate readings. The time period between calibrations, and the rate of system drift, can vary considerably with each application and its specific conditions.



**Calibration Tip!** Establish a maintenance program to keep the sensor relatively clean and the analyzer calibrated. The daily, weekly or monthly intervals between performing maintenance will be influenced by the characteristics of the process solution, and can only be determined by operating experience.

Temperature-corrected  
pH Measurement

The analyzer is factory-calibrated for accurate temperature measurement. It will provide pH readings that are automatically corrected for temperature changes when the analyzer:

- Receives a temperature signal from a pH sensor that has a built-in temperature element (all GLI Differential sensors) or from an external temperature element.
- Has been correctly set for the type of temperature element being used for automatic compensation.



**NOTE:** When the passcode feature is enabled (Section 4.6), you must successfully enter the passcode before attempting to calibrate the analyzer.

**Also, an in-progress calibration can always be aborted by pressing the ESC key. After the “ABORT: YES?” screen appears, do one of the following:**

- Press **ENTER key** to abort. After the “CONFIRM ACTIVE?” screen appears, press **ENTER key** to return the analog outputs and relays to their active states (MEASURE screen appears).
- Press **↑ or ↓ key** to choose “ABORT: NO?” screen, and press **ENTER key** to continue calibration.



**Calibration Tip!** If a “CONFIRM FAILURE?” screen appears during calibration, press **ENTER key** to confirm. Then, use **↑ or ↓ key** to select between “CAL: EXIT?” or “CAL: REPEAT?” and do one of the following:

- With the “(CAL: EXIT)” screen selected, press **ENTER key**. After the “CONFIRM ACTIVE?” screen appears, press **ENTER key** to return the analog outputs and relays to their active states (MEASURE screen appears).
- With the “(CAL: REPEAT)” screen selected, press **ENTER key** to repeat calibration of the point.

## 5.2 pH Calibration

Based on convenience and your application requirements, use one of the four methods provided for pH calibration.

### CAUTION:

**WHEN USING A NEW SENSOR OR REPLACING THE SALT BRIDGE AND STANDARD CELL SOLUTION ON AN EXISTING SENSOR, ALWAYS PERFORM A “RESET CAL” USING THE TEST/MAINT MENU (PART THREE, SECTION 6.10) BEFORE CALIBRATING.**



**NOTE:** *When calibrating a sensor for the first time, always use a two-point method for best accuracy.*

### 2 POINT BUFFER Method

This recommended method requires two buffers, typically pH 7 and pH 4. (pH 10 buffer is also readily available but is not as stable, particularly at extreme temperatures.) This method automatically recognizes buffers from the selected buffer set. **Therefore, you must use buffers that match values in the buffer set** (see PART THREE, Section 4.2, subheading “SELECT BUFFER Set for pH Calibration” for details.)



**NOTE:** *When using buffers that are not included in either of the analyzer buffer sets, disregard this calibration method. Instead, use only the “2 POINT SAMPLE” calibration method.*

1. Immerse the sensor in the first pH buffer (preferably pH 7). **Important: Allow the sensor and buffer temperatures to equalize.** Depending on their temperature differences, this may take 30 minutes or more.

```

MAIN MENU
▶CALIBRATE
▶CONFIGURE
▶TEST/MAINT
◀EXIT
  
```

2. Press **MENU** key to display .
3. With the “CALIBRATE” line selected, press **ENTER** key

```

CALIBRATE
▶SENSOR
▶CAL OUTPUTS
◀EXIT
  
```

to display .

4. With the “SENSOR” line selected, press **ENTER** key to

```

SENSOR
▶2 POINT BUFFER
▶1 POINT BUFFER
▶2 POINT SAMPLE
▶1 POINT SAMPLE
◀EXIT
  
```

display .

5. With the “2 POINT BUFFER” line selected, press **ENTER** key to display 

```
2 POINT BUFFER?
(HOLD OUTPUTS )
```

 . Use **↑** or **↓** key to view the three states that the analog outputs (and relays) can be in during calibration:

- **HOLD OUTPUTS:** Holds their present values.
- **XFER OUTPUTS:** Transfers to preset values.
- **ACTIVE OUTPUTS:** Responds to measured values.

With the desired choice displayed, press **ENTER** key to enter this selection.

6. With the sensor in the first buffer and the 

```
2 POINT BUFFER:
IN 1ST SOLUTION?
```

 screen displayed, press **ENTER** key to confirm.

While the 

```
2 POINT BUFFER:
PLEASE WAIT
```

 screen is displayed, the analyzer waits for the pH and temperature signals to stabilize, measures the buffer value, and automatically calibrates this point.

Thereafter, a screen like 

```
2 POINT BUFFER:
PT1 = 7.00 pH
```

 appears for 5 seconds to confirm calibration of this point.



**NOTE:** Any time the “PLEASE WAIT” screen appears during calibration, you can manually complete

*calibration of the point by pressing the **ENTER** key. However, this is not recommended because the pH and temperature signals may not be fully stabilized, resulting in a less accurate calibration.*

7. After the 

2 POINT BUFFER: IN 2ND SOLUTION?
-------------------------------------

 screen appears, remove the sensor from the first buffer, rinse it with clean water, and immerse it in the second buffer (typically 4 pH).
8. Press **ENTER** key to confirm this.

While the 

2 POINT BUFFER: PLEASE WAIT
--------------------------------

 screen is displayed, the analyzer waits for the pH and temperature signals to stabilize, measures the buffer value, and automatically calibrates this point.

Thereafter, a screen like 

2 POINT BUFFER: PT2 = 4.00 pH
----------------------------------

 appears for 5 seconds to confirm calibration of this point.

9. A “pH SLOPE XX.X mV/pH” screen appears, indicating a slope value to measure sensor performance. The slope should be between 54 and 62 mV/pH for optimal sensor performance. Typically, as the sensor ages and/or becomes dirty, its slope decreases. When the slope is less than 54 mV/pH, clean the sensor to improve its performance. If you are using a GLI Differential sensor and the slope remains low, replace the salt bridge and standard cell solution (see sensor operating manual for details). If using a conventional combination electrode, consider replacing it.
10. Press **ENTER** key to end calibration (“2 POINT BUFFER: CONFIRM CAL OK?” screen appears).
11. Re-install the sensor into the process.
12. Press **ENTER** key to display the active measurement reading on the “2 POINT BUFFER: CONFIRM ACTIVE?” output status screen. When the reading corresponds to the actual typical process value, press **ENTER** key again to return the analog outputs and relays to their active states (MEASURE screen appears).

This completes “2 POINT BUFFER” calibration.

## 1 POINT BUFFER Method

This method is similar to the 2 POINT BUFFER method except that only one buffer is used to calibrate one point. This method also automatically recognizes buffers from the buffer set you selected. Therefore, you must use a buffer that matches a value in the buffer set. (See PART THREE, Section 4.2 subheading “SELECT BUFFER Set for pH Calibration” for details.)



**NOTE:** When using a buffer that is not included in either of the analyzer buffer sets, disregard this calibration method. Instead, use only the “1 POINT SAMPLE” calibration method.

1. Immerse the sensor in the pH buffer. **Important: Allow the sensor and buffer temperatures to equalize.** Depending on their temperature differences, this may take 30 minutes or more.

```

MAIN MENU
├── CALIBRATE
├── CONFIGURE
├── TEST/MAINT
└── EXIT
  
```

2. Press **MENU** key to display .
3. With the “CALIBRATE” line selected, press **ENTER** key

```

CALIBRATE
├── SENSOR
├── CAL OUTPUTS
└── EXIT
  
```

to display .

4. With the “SENSOR” line selected, press **ENTER** key to

```

SENSOR
├── 2 POINT BUFFER
├── 1 POINT BUFFER
├── 2 POINT SAMPLE
├── 1 POINT SAMPLE
└── EXIT
  
```

display .

5. Use ↓ **key** to select the “1 POINT BUFFER” line and press **ENTER** key to display 

```
1 POINT BUFFER?
(HOLD OUTPUTS )
```

 . Use ↑ or ↓ **key** to view the three states that the analog outputs (and relays) can be in during calibration:

- **HOLD OUTPUTS:** Holds their present values.
- **XFER OUTPUTS:** Transfers to preset values.
- **ACTIVE OUTPUTS:** Responds to measured values.

With the desired choice displayed, press **ENTER** key to enter this selection.

6. With the sensor in the buffer and the 1 POINT BUFFER:  
SAMPLE READY? screen displayed, press **ENTER key** to confirm.

While the 1 POINT BUFFER:  
PLEASE WAIT screen is displayed, the analyzer waits for the pH and temperature signals to stabilize, measures the buffer value, and automatically calibrates the point.

Thereafter, a screen like 1 POINT BUFFER:  
PT = 7.00 pH appears for 5 seconds to confirm calibration of the point.



**NOTE:** Any time the “PLEASE WAIT” screen appears during calibration, you can manually complete calibration of the point by pressing the **ENTER key**. However, this is not recommended because the pH and temperature signals may not be fully stabilized, resulting in a less accurate calibration.

7. A “pH SLOPE XX.X mV/pH” screen appears, indicating a slope value to measure sensor performance. The slope should be between 54 and 62 mV/pH for optimal sensor performance. Typically, as the sensor ages and/or becomes dirty, its slope decreases. When the slope is less than 54 mV/pH, clean the sensor to improve its performance. If you are using a GLI Differential sensor and the slope remains low, replace the salt bridge and standard cell solution (see sensor operating manual for details). If using a conventional combination electrode, consider replacing it.
8. Press **ENTER key** to end calibration (“1 POINT BUFFER: CONFIRM CAL OK?” screen appears).
9. Re-install the sensor into the process.
10. Press **ENTER key** to display the active measurement reading on the “1 POINT BUFFER: CONFIRM ACTIVE?” output status screen. When the reading corresponds to the actual typical process value, press **ENTER key** again to return the analog outputs and relays to their normal states (MEASURE screen appears).

This completes “1 POINT BUFFER” calibration.

## 2 POINT SAMPLE Method

This method requires you to enter the known pH values of two process samples (or two pH buffers). Determine sample values using laboratory analysis or comparison readings.

1. Immerse the sensor in the first solution (sample or buffer). **Important: Allow the sensor and sample temperatures to equalize.** Depending on their temperature differences, this may take 30 minutes or more.

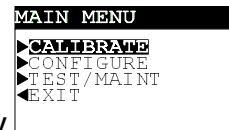

2. Press **MENU** key to display

3. With the “CALIBRATE” line selected, press **ENTER** key

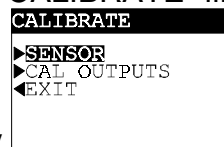

to display

4. With the “SENSOR” line selected, press **ENTER** key to

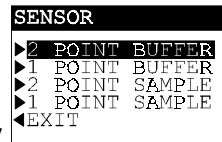

display

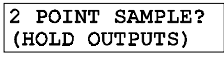
5. Use **↓** key to select the “2 POINT SAMPLE” line and press **ENTER** key to display . Use **↑** or **↓** key to view the three states that the analog outputs (and relays) can be in during calibration:

- **HOLD OUTPUTS:** Holds their present values.
- **XFER OUTPUTS:** Transfers to preset values.
- **ACTIVE OUTPUTS:** Responds to measured values.

With the desired choice displayed, press **ENTER** key to enter this selection.

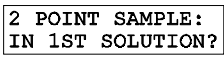
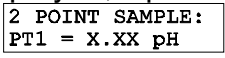
6. With the sensor in the first solution (sample or buffer) and the  screen displayed, press **ENTER** key to confirm. This active  screen appears showing the measurement reading.

7. Wait for the reading to stabilize which may take up to 30 minutes. Then press **ENTER** key. The “PLEASE WAIT” screen may appear if the reading is still too unstable. After the reading has stabilized, this static

- 2 POINT SAMPLE?  
(X.XX pH ) screen appears showing the “last” measured value.
8. Determine the pH value of the first solution. For a sample, use laboratory analysis or a calibrated portable pH meter. (When using a pH buffer, refer to the table on the buffer bottle to find the exact pH value corresponding to the temperature of the buffer.)
  9. With the static 2 POINT SAMPLE?  
(X.XX pH ) screen displayed, use **arrow keys** to adjust the displayed value to exactly match the known pH value of the first solution (sample or buffer). Then press **ENTER key** to enter the value and complete calibration of the first point.
  10. After the 2 POINT SAMPLE:  
IN 2ND SOLUTION? screen appears, remove the sensor from the first solution, and rinse it with clean water.
  11. Immerse the sensor in the second solution, and press **ENTER key** to confirm. This active 2 POINT SAMPLE:  
PT2 = X.XX pH screen appears showing the measurement reading.
  12. Wait for the reading to stabilize which may take up to 30 minutes. Then press **ENTER key**. The “PLEASE WAIT” screen may appear if the reading is still too unstable. After the reading has stabilized, this static 2 POINT SAMPLE?  
(X.XX pH ) screen appears showing the “last” measured value.
  13. Determine the pH value of the second solution.
  14. With the static 2 POINT SAMPLE?  
(X.XX pH ) screen displayed, use **arrow keys** to adjust the displayed value to exactly match the known pH value of the second solution. Then press **ENTER key** to enter the value, completing calibration of the second point.
  15. A “pH SLOPE XX.X mV/pH” screen appears, indicating a slope value to measure sensor performance. The slope should be between 54 and 62 mV/pH for optimal sensor performance. Typically, as the sensor ages and/or becomes dirty, its slope decreases. When the slope is less than 54 mV/pH, clean the sensor to improve its performance. If you are using a GLI

Differential sensor and the slope remains low, replace the salt bridge and standard cell solution (see sensor operating manual for details). If using a conventional combination electrode, consider replacing it.

- 16. Press **ENTER key** to end calibration (“2 POINT SAMPLE: CONFIRM CAL OK?” screen appears).
- 17. Re-install the sensor into the process.
- 18. Press **ENTER key** to display the active measurement reading on the “2 POINT SAMPLE: CONFIRM ACTIVE?” output status screen. When the reading corresponds to the actual typical process value, press **ENTER key** again to return the analog outputs and relays to their active states (MEASURE screen appears).

This completes “2 POINT SAMPLE” calibration.

### 1 POINT SAMPLE Method

This method is similar to the 2 POINT SAMPLE method except that only one sample (or buffer) is used to calibrate one point. This method requires you to enter the known pH value of the sample (or pH buffer). Determine the sample value using laboratory analysis or a comparison reading.

- 1. Immerse the sensor in the sample (or buffer). **Important: Allow the sensor and sample temperatures to equalize.** Depending on their temperature differences, this may take 30 minutes or more.

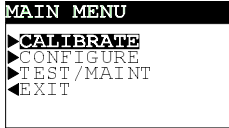
- 2. Press **MENU key** to display  .

- 3. With the “CALIBRATE” line selected, press **ENTER key**

to display  .

- 4. With the “SENSOR” line selected, press **ENTER key** to

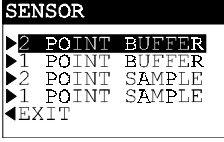
display  .

5. Use  $\downarrow$  **key** to select the “1 POINT SAMPLE” line and press **ENTER key** to display 

1 POINT SAMPLE? (HOLD OUTPUTS )
------------------------------------

. Use  $\uparrow$  or  $\downarrow$  **key** to view the three states that the analog outputs (and relays) can be in during calibration:
- **HOLD OUTPUTS:** Holds their present values.
  - **XFER OUTPUTS:** Transfers to preset values.
  - **ACTIVE OUTPUTS:** Responds to measured values.

With the desired choice displayed, press **ENTER key** to enter this selection.

6. With the sensor in the sample (or buffer) and the 

1 POINT SAMPLE: SAMPLE READY?
----------------------------------

 screen displayed, press **ENTER key** to confirm. This active

1 POINT SAMPLE: PT = X.XX pH
---------------------------------

 screen appears showing the measurement reading.
7. Wait for the reading to stabilize which may take up to 30 minutes. Then press **ENTER key**. The “PLEASE WAIT” screen may appear if the reading is still too unstable. After the reading has stabilized, this static

1 POINT SAMPLE? (X.XX pH )
-------------------------------

 screen appears showing the “last” measured value.
8. Determine the pH value of the sample using laboratory analysis or a calibrated portable pH meter. (When using a pH buffer, refer to the table on the buffer bottle to find the exact pH value corresponding to the temperature of the buffer.)
9. With the static

1 POINT SAMPLE? (X.XX pH )
-------------------------------

 screen displayed, use **arrow keys** to adjust the displayed value to exactly match the known pH value of the sample (or buffer). Then press **ENTER key** to enter the value, completing calibration of the point.
10. A “pH SLOPE XX.X mV/pH” screen appears, indicating a slope value to measure sensor performance. The slope should be between 54 and 62 mV/pH for optimal sensor performance. Typically, as the sensor ages and/or becomes dirty, its slope decreases. When the slope is less than 54 mV/pH, clean the sensor to improve its performance. If you are using a GLI Differential sensor and the slope remains low, replace the salt bridge and standard cell solution (see sensor

operating manual for details). If using a conventional combination electrode, consider replacing it.

11. Press **ENTER key** to end calibration (“1 POINT SAMPLE: CONFIRM CAL OK?” screen appears).
12. Re-install the sensor into the process.
13. Press **ENTER key** to display the active measurement reading on the “1 POINT SAMPLE: CONFIRM ACTIVE?” output status screen. When the reading corresponds to the actual typical process value, press **ENTER key** again to return the analog outputs and relays to their active states (MEASURE screen appears).

This completes “1 POINT SAMPLE” calibration.

### 5.3 ORP Calibration

Calibrate for ORP measurement using only this “1 POINT SAMPLE” method.

#### CAUTION:



**WHEN USING A NEW SENSOR OR REPLACING THE SALT BRIDGE AND STANDARD CELL SOLUTION ON AN EXISTING SENSOR, ALWAYS PERFORM A “RESET CAL” USING THE TEST/MAINT MENU (PART THREE, SECTION 6.10) BEFORE CALIBRATING.**



**NOTE:** *A two-point calibration method is purposely excluded since it could provide bad results. Immersing the sensor into one reference solution and then into the other could contaminate electrochemical components of the sensor.*

This method requires you to enter the known mV value of a sample (or reference solution). Determine the sample mV value using laboratory analysis or a comparison reading.

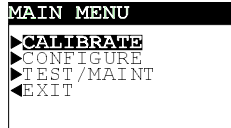
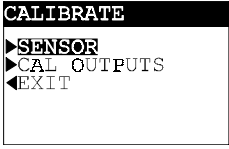
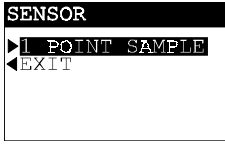
1. Immerse the sensor in the sample (or reference solution).

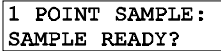
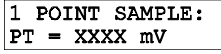
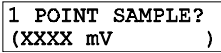
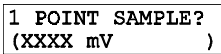
2. Press **MENU** key to display  .
3. With the “CALIBRATE” line selected, press **ENTER** key to display  .
4. With the “SENSOR” line selected, press **ENTER** key to display  .
5. With the “1 POINT SAMPLE” line selected, press **ENTER** key to display  . Use **↑** or **↓** key to view the three states that the analog outputs (and relays) can be in during calibration:
- **HOLD OUTPUTS:** Holds their present values.
  - **XFER OUTPUTS:** Transfers to preset values.
  - **ACTIVE OUTPUTS:** Responds to measured values.
- With the desired choice displayed, press **ENTER** key to enter this selection.
6. With the sensor in the sample (or reference solution) and the  screen displayed, press **ENTER** key to confirm. This active  screen appears showing the measurement reading.
7. Wait for the reading to stabilize. Then press **ENTER** key. The “PLEASE WAIT” screen may appear if the reading is still too unstable. After the reading has stabilized, this static  screen appears showing the “last” measured value.
8. If not using an ORP reference solution, determine the mV value of the sample using laboratory analysis or a calibrated portable ORP meter.
9. With the static  screen displayed, use **arrow keys** to adjust the displayed value to exactly

match the known mV value of the sample (or reference solution). Then press **ENTER key** to enter the value, completing calibration of the point.

10. Press **ENTER key** again to end calibration (“1 POINT SAMPLE: CONFIRM CAL OK?” screen appears).
11. Re-install the sensor into the process.
12. Press **ENTER key** to display the active measurement reading on the “1 POINT SAMPLE: CONFIRM ACTIVE?” output status screen. When the reading corresponds to the actual typical process value, press **ENTER key** again to return the analog outputs and relays to their active states (MEASURE screen appears).

This completes ORP calibration.

## 5.4 Analog Outputs (1 and 2) Calibration



The analyzer analog outputs are factory-calibrated. However, they can be re-calibrated at any time if desired. **These instructions calibrate Output 1. Calibrate Output 2 in the same way using its respective menu screens.**

**NOTE:** When the passcode feature is enabled (Section 4.6), you must successfully enter the passcode before attempting to calibrate the analog outputs.

When an output is configured to be 0-20 mA, the analyzer will calibrate the 4 mA and 20 mA values (not the 0 mA value). Also, the analyzer adjustment range for output values during calibration is  $\pm 2$  mA.

```

MAIN MENU
▶CALIBRATE
▶CONFIGURE
▶TEST/MAINT
◀EXIT
  
```

1. Press **MENU key** to display .
2. With the “CALIBRATE” line selected, press **ENTER key**

```

CALIBRATE
▶SENSOR
▶CAL OUTPUTS
◀EXIT
  
```

to display .

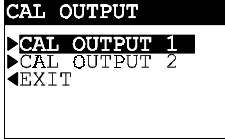
3. Use **↓ key** to select the “CAL OUTPUTS” line, and  

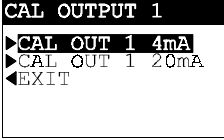
press **ENTER key** to display .
4. With the “CAL OUTPUT 1” line selected, press  

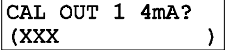
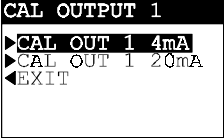
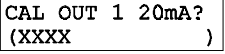
**ENTER key** to display .
5. With the “CAL OUT 1 4 mA” line selected, press  
**ENTER key** to display a screen like  .  
 The displayed value is “counts” -- not mA -- that dynamically change when the output is adjusted.
6. Use a calibrated digital multimeter to measure Output 1’s actual minimum value provided at Terminals 2 and 3 on TB1.
7. Use **arrow keys** to adjust Output 1’s minimum value to read exactly “4.00 mA” on the digital multimeter -- not the analyzer display, and press **ENTER key** to complete calibration of the minimum endpoint value.
8. After the  screen re-appears, press **↓ key** once to select the “CAL OUT 1 20 mA” line, and press **ENTER key** to display a screen like  . Once again the displayed value is “counts” -- not mA -- that dynamically change when the output is adjusted.
9. Use a calibrated digital multimeter to measure Output 1’s actual maximum value.
10. Use **arrow keys** to adjust Output 1’s maximum value to read exactly “20.00 mA” on the digital multimeter -- not the analyzer display, and press **ENTER key** to complete calibration of the maximum endpoint value.

This completes analog Output 1 calibration.

# SECTION 6

## TEST/MAINTENANCE

The analyzer has TEST/MAINT menu screens to:

- Check operating status of the analyzer, sensor, and relays, including TIMER relay countdown.
- Hold analog outputs at their last measured values.
- Manually reset all relay overfeed timers at once.
- Provide analog output test signals to confirm operation of connected devices.
- Test relay operation (energize or de-energize).
- Identify analyzer EPROM version.
- Simulate a pH (or mV) or temperature signal to exercise the measurement loop.
- Reset configuration -- not calibration -- values to defaults.
- Reset calibration -- not configuration -- values to defaults.

### 6.1 STATUS Checking (analyzer, sensor, and relays)

The system diagnostic capabilities of the analyzer enable you to check the operating status of the analyzer, sensor (measurement and temperature signals), and relays. The MEASURE screen will flash the “WARNING CHECK STATUS” message when a sensor or analyzer diagnostic “fail” condition has been detected. To determine the condition causing the warning, display the “STATUS” screens:



1. Press **MENU** key to display  , and use **↓** key to select the “TEST/MAINT” line.

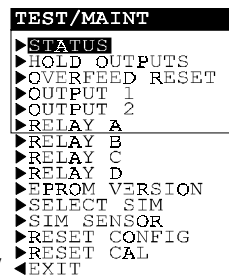

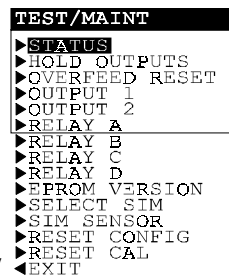
2. Press **ENTER** key to display  .
3. With the “STATUS” line selected, press **ENTER** key to display the “STATUS: ANALYZER OK” screen. This screen confirms that the analyzer is operating properly. If “FAIL” appears, it may mean:

- EPROM failure (data is not valid).
  - Scaling card not present or not recognized.
  - Analog-to-digital converter not responding.
  - RAM failure.
  - Internal serial communications failure.
4. Press **ENTER key** again to view the “STATUS: SENSOR OK” screen. If “FAIL” appears, it indicates that the sensor is inoperative or its signal is out of range (more than +480 mV or less than -480 mV for pH; more than +2100 mV or less than -2100 mV for ORP).
  5. Press **ENTER key** again to view the “STATUS: TEMP OK” screen. If “FAIL” appears, it indicates that the temperature element in the sensor (or an external element) is inoperative, disconnected or incorrectly wired.
  6. With the “STATUS: TEMP OK” screen displayed, press **ENTER key** once to view the “STATUS: RLY A” screen. Subsequent **ENTER key** presses display status screens for Relay B, C, and D. Status indications can be:

Status Indication	Meaning
ACTIVE (Relay energized; annunciator is on.)	Control Relay: Measured value exceeds setpoint. Alarm Relay: Measured value exceeds low or high alarm point. Status Relay: Existing system diagnostic condition has been detected.
INACTIVE (Relay not energized; annunciator is off.)	Control Relay: Measured value does not exceed setpoint. Alarm Relay: Measured value does not exceed low or high alarm point. Status Relay: Analyzer has not detected system diagnostic condition.
TIMEOUT (Relay not energized; annunciator blinks.)	Control Relay: Overfeed timer has timed out; manually reset it. <b>NOTE: TIMEOUT only applies to control relays.</b>
COUNTING (Relay energized; annunciator is on.)	Control Relay: Overfeed timer is counting, but has not timed out. <b>NOTE: COUNTING only applies to control relays.</b>
TIME ON (Relay energized; annunciator is on.)	Timer Relay: Timer relay is on and counting down duration time before turning off. <b>NOTE: TIME ON only applies to timer relays.</b>
TIME OFF (Relay not energized; annunciator is off.)	Timer Relay: Timer relay is off and counting down interval time before turning on. <b>NOTE: TIME OFF only applies to timer relays.</b>

7. To end status checking, press **ESC key** or **ENTER key** (display returns to TEST/MAINT top-level menu screen).

## 6.2 HOLD OUTPUTS

The analyzer has a convenient feature to hold the analog outputs at their last measured values for up to 30 minutes, suspending operation of any connected devices.

```

TEST/MAINT
▶STATUS
▶HOLD OUTPUTS
▶OVERFEED RESET
▶OUTPUT 1
▶OUTPUT 2
▶RELAY A
▶RELAY B
▶RELAY C
▶RELAY D
▶EPROM VERSION
▶SELECT SIM
▶SIM SENSOR
▶RESET CONFIG
▶RESET CAL
◀EXIT
  
```

1. With the  screen displayed, use **↓ key** to select the “HOLD OUTPUTS” line.
2. Press **ENTER key** to immediately hold the analog outputs (“HOLD OUTPUTS: ENTER TO RELEASE” screen appears, acknowledging hold is applied).

**NOTE:** *If the keypad is not used within 30 minutes, the analog outputs will automatically change back to their active states and the display will return to the MEASURE screen.*

3. To release the hold at any time and return analog outputs back to their “active” states, press **ENTER key** (display returns to TEST/MAINT top-level menu screen).

## 6.3 OVERFEED RESET (relay timers)

When a relay overfeed timer “times out,” as indicated by its blinking annunciator, the timer must be manually reset using TEST/MAINT menu screens. The relay annunciator stops blinking after reset. **All overfeed timers are manually reset at once.**

```

TEST/MAINT
▶STATUS
▶HOLD OUTPUTS
▶OVERFEED RESET
▶OUTPUT 1
▶OUTPUT 2
▶RELAY A
▶RELAY B
▶RELAY C
▶RELAY D
▶EPROM VERSION
▶SELECT SIM
▶SIM SENSOR
▶RESET CONFIG
▶RESET CAL
◀EXIT
  
```

1. With the  screen displayed, use **↓ key** to select the “OVERFEED RESET” line.
2. Press **ENTER key** to display “OVERFEED RESET: DONE” screen, acknowledging all relay overfeed timers have been reset.
3. To return to the TEST/MAINT top-level menu screen, press **ESC key** or **ENTER key**.

## 6.4 OUTPUT (1 and 2) Analog Test Signals

The analyzer can provide analog output test signals of a desired mA value to confirm operation of connected devices. **These instructions provide an Output 1 test signal. Provide an Output 2 test signal in the same way using its respective menu screens.**

```

TEST/MAINT
▶STATUS
▶HOLD OUTPUTS
▶OVERFEED RESET
▶OUTPUT 1
▶OUTPUT 2
▶RELAY A
▶RELAY B
▶RELAY C
▶RELAY D
▶EPROM VERSION
▶SELECT SIM
▶SIM SENSOR
▶RESET CONFIG
▶RESET CAL
◀EXIT
  
```

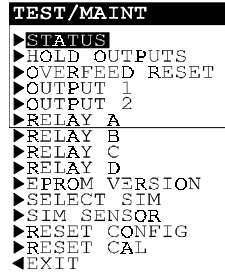
1. With the  screen displayed, use **↓ key** to select the “OUTPUT 1” line.

2. Press **ENTER key** to display a screen like

```

OUTPUT 1?
(XX.XXmA )
  
```



**NOTE:** *The mA test signal for Output 1 is now active. Its value is shown on this screen.*

3. Use **arrow keys** to adjust the displayed value to obtain the desired mA test signal at Output 1 terminals.
4. To remove the output test signal and return to the TEST/MAINT top-level menu screen, press **ESC key** or **ENTER key**.

## 6.5 RELAY (A, B, C, and D) Operating Test

Relays A, B, C, and D can be tested to confirm their operation. **These instructions test Relay A. Test other relays in the same way using their respective menu screens.**

```

TEST/MAINT
▶STATUS
▶HOLD OUTPUTS
▶OVERFEED RESET
▶OUTPUT 1
▶OUTPUT 2
▶RELAY A
▶RELAY B
▶RELAY C
▶RELAY D
▶EPROM VERSION
▶SELECT SIM
▶SIM SENSOR
▶RESET CONFIG
▶RESET CAL
◀EXIT
  
```

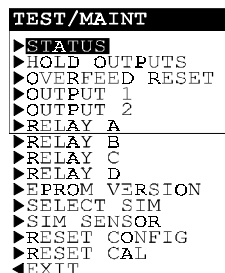
1. With the  screen displayed, use **↓ key** to select the “RELAY A” line.

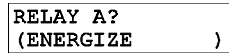
2. Press **ENTER key** to display . Relay A should be energized. Confirm this by checking its NO and NC relay output terminals with a continuity meter.

3. Press **↑** or **↓** **key once** to display RELAY A?  
(DE-ENERGIZE ) .  
Relay A should now be de-energized. Confirm this by checking its NO and NC relay output terminals with a continuity meter.
4. To end this test and return to the TEST/MAINT top-level menu screen, press **ESC key** or **ENTER key**.

### 6.6 EPROM VERSION Checking

You can check the version of EPROM used in the analyzer.

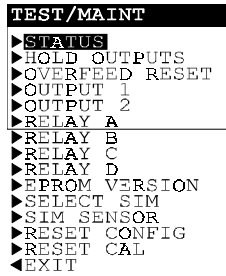

1. With the RELAY A?  
(DE-ENERGIZE ) screen displayed, use **↓** **key** to select the “EPROM VERSION” line.
2. Press **ENTER key** to view the EPROM version screen.
3. To return to the TEST/MAINT top-level menu screen, press **ESC key** or **ENTER key**.

### 6.7 SELECT SIM Measurement

You can simulate a measured value to make the relays and analog outputs respond accordingly. First, select the type of simulated value using this subsection. Then, set the desired simulation value following the steps in subsection 6.8.

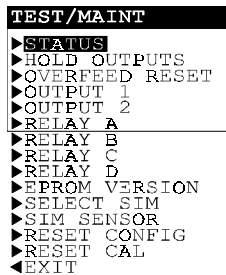

1. With the RELAY A?  
(DE-ENERGIZE ) screen displayed, use **↓** **key** to select the “SELECT SIM” line.
2. Press **ENTER key** to display a screen like SELECT SIM?  
(SENSOR ) . Use **↓** and **↑** **keys** to view both choices:

## 6.8 SIM SENSOR Setting

- **SENSOR:** Selects the simulated value to be a pH (or ORP) value.
- **TEMPERATURE:** Selects the simulated value to be a temperature value.

3. With the desired choice displayed, press **ENTER key** to enter this selection and return to the TEST/MAINT top-level menu screen.

After selecting the type of simulated measurement (subsection 6.7), set the desired simulation value.

```

TEST/MAINT
▶STATUS
▶HOLD OUTPUTS
▶OVERFEED RESET
▶OUTPUT 1
▶OUTPUT 2
▶RELAY A
▶RELAY B
▶RELAY C
▶RELAY D
▶EPROM VERSION
▶SELECT SIM
▶SIM SENSOR
▶RESET CONFIG
▶RESET CAL
◀EXIT
  
```

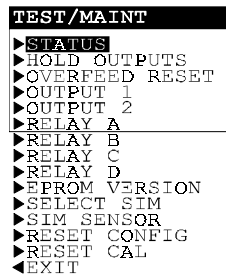
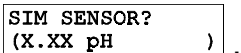
1. With the  screen displayed, use **↓ key** to select the “SIM SENSOR” line.
2. Press **ENTER key** to display a screen like .



**NOTE:** Both analog output signals are now active. They have a mA value that corresponds to the measurement value shown on this screen. (The relays, depending on their configured settings, may also respond to this simulation value.)

3. Use **arrow keys** to adjust the displayed simulation value to the desired value.
4. To remove the simulated output and return to the TEST/MAINT top-level menu screen, press **ESC key** or **ENTER key**.

## 6.9 RESET CONFIG Values to Factory Defaults

You can conveniently reset all stored configuration settings -- **but not calibration settings** -- (all at the same time) to their factory-set defaults shown in Table B.

```

TEST/MAINT
▶STATUS
▶HOLD OUTPUTS
▶OVERFEED RESET
▶OUTPUT 1
▶OUTPUT 2
▶RELAY A
▶RELAY B
▶RELAY C
▶RELAY D
▶EPROM VERSION
▶SELECT SIM
▶SIM SENSOR
▶RESET CONFIG
▶RESET CAL
◀EXIT

```

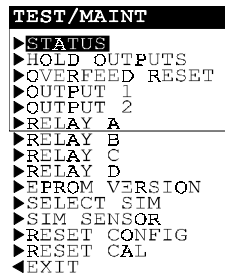
1. With the  screen displayed, use **↓ key** to select the “RESET CONFIG” line.
2. Press **ENTER key** to display the “RESET CONFIG: ARE YOU SURE?” screen, asking if you really intend to perform this extreme action. (To abort this procedure, press **ESC key** now.)
3. Press **ENTER key** to reset all stored configuration settings -- **not calibration settings** -- to factory defaults. The “RESET CONFIG: DONE” screen appears, acknowledging that reset has occurred.
4. To return to the TEST/MAINT top-level menu screen, press **ESC key** or **ENTER key**.

## 6.10 RESET CAL Values to Factory Defaults

You can conveniently reset all stored calibration settings -- **but not configuration settings** -- to factory-set defaults.

```

TEST/MAINT
▶STATUS
▶HOLD OUTPUTS
▶OVERFEED RESET
▶OUTPUT 1
▶OUTPUT 2
▶RELAY A
▶RELAY B
▶RELAY C
▶RELAY D
▶EPROM VERSION
▶SELECT SIM
▶SIM SENSOR
▶RESET CONFIG
▶RESET CAL
◀EXIT

```

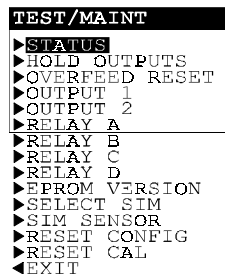
1. With the  screen displayed, use **↓ key** to select the “RESET CAL” line.
2. Press **ENTER key** to display the “RESET CAL: ARE YOU SURE?” screen, asking if you really intend to perform this extreme action. (To abort this procedure, press **ESC key** now.)
3. Press **ENTER key** to reset all stored calibration settings -- **not configuration settings** -- to factory defaults. The “RESET CAL: DONE” screen appears, acknowledging that reset has occurred.
4. To return to the “TEST/MAINT” top-level menu screen, press **ESC key** or **ENTER key**.

## SECTION 7

## RELAY OVERFEED TIMER FEATURE

### 7.1 Why Use an Overfeed Timer

The useful relay overfeed timer feature, **only available to a CONTROL relay**, is described in more detail in this section.

Suppose that you configure a CONTROL relay with a high phase to operate in response to increasing measured value. The CONTROL relay will then turn on whenever the measured value exceeds its preset setpoint. When the measured value decreases below the setpoint by an amount you preset (the deadband setting), the relay will turn off. But what if a damaged sensor or a process upset condition keeps the measured value above the setpoint or deadband setting? The control element (valve, pump, etc.) switched by that relay would then continue to operate. Depending on the application control scheme, this may excessively dispense costly chemical additives or overly drain or divert the process. Also, the control element itself could be damaged due to excessive continuous or unusual operation such as a pump that is running dry. The useful overfeed timer prevents undesirable conditions like these from happening. It restricts how long the relay and its connected control element will remain on regardless of conditions.

### 7.2 Configuring Relay Overfeed Timers

To set a relay overfeed timer, use its respective configuration menu screen. The time you set to restrict how long the relay stays on (0-999.9 minutes) should be just enough to provide acceptable results. An excessive setting may waste chemicals or the process itself. Initially, set this time as an estimate. Then, by experimenting and observing the response, periodically “fine tune” to optimize the setting.

### 7.3 Overfeed Timer “Timeout” Operation

When a CONTROL relay is on and its overfeed timer “times out,” its annunciator will blink. This indicates that the relay is now off and will remain off until you manually reset the overfeed timer. After reset, the relay annunciator stops blinking. (All overfeed timers are reset simultaneously.)

### 7.4 Resetting Overfeed Timers

To manually reset all relay overfeed timers, please refer to PART THREE, Section 6.3.

### 7.5 Interactions with Other Analyzer Functions

A relay overfeed timer can, and often will, interact with other analyzer functions while those functions are in use. Table C on the next page explains common overfeed timer interactions.

<b>Table C -- RELAY OVERFEED TIMER INTERACTIONS WITH OTHER ANALYZER FUNCTIONS</b>		
Function Conditions		Resulting Action of Overfeed Timer
<b>Manually Holding Relay Operation (when outputs are held at start of calibration)</b>		
Off relay held in "off"	Overfeed timer was off	Overfeed timer remains off. After you change back to ACTIVE from the HOLD mode, the overfeed timer will remain off until the measured value (or a value you simulate) causes the relay to turn on.
On relay held in "on"	Overfeed timer was counting	Overfeed timer continues its "count down" until it turns the relay off. If you release HOLD <u>before</u> the timer "times out," the timer continues its "count down" until it turns the relay off or the timer automatically resets when the measured value (or a value you simulate) causes the relay to turn off. If you release HOLD <u>after</u> the timer has "timed out," it must be manually reset (PART THREE, Section 6.3).
On relay held in "on"	Overfeed timer was timed out	Overfeed timer remains off which keeps the relay turned off. You must manually reset the timer (PART THREE, Section 6.3).
<b>Manually Transferring Relay Operation (when outputs are transferred at start of calibration)</b>		
Off relay is transferred to "on"	Overfeed timer was off	Overfeed timer starts its "count down" until it turns the relay off. After you change the "on" relay back to "off," the overfeed timer automatically resets.
On relay is transferred to "off"	Overfeed timer was counting	Overfeed timer automatically resets. After you change the "off" relay back to "on," the overfeed timer starts its "count down" until it turns the relay off, or the timer automatically resets again when the measured value (or a value you simulate) causes the relay to turn off.
On relay is transferred to "off"	Overfeed timer was timed out	
<b>Manually Testing Relay Operation (by using TEST/MAINT menu screens)</b>		
Off relay is changed to "on"	Overfeed timer was off	Overfeed timer starts its "count down" until it turns the relay off. After you change the "on" relay back to "off," the overfeed timer automatically resets.
On relay is changed to "off"	Overfeed timer was counting	Overfeed timer automatically resets. After you change the "off" relay back to "on," the overfeed timer starts its "count down" until it turns the relay off, or the timer automatically resets again when the measured value (or a value you simulate) causes the relay to turn off.
On relay is changed to "off"	Overfeed timer was timed out	
<b>Operating a Relay By Simulating a Value (by using TEST/MAINT menu screens)</b>		
Off relay is turned "on" by simulated value	Overfeed timer was off	Overfeed timer starts its "count down" until it turns the relay off. After you change the "on" relay back to "off," the overfeed timer automatically resets.
On relay is turned "off" by simulated value	Overfeed timer was counting	Overfeed timer automatically resets. After you change the "off" relay back to "on," the overfeed timer starts its "count down" until it turns the relay off, or the timer automatically resets again when the measured value (or a value you simulate) causes the relay to turn off.
On relay is turned "off" by simulation value	Overfeed timer was timed out	

## SECTION 8

### HART OPTION

#### 8.1 Introduction

Your GLI analyzer may be equipped with the HART<sup>®</sup> Field Communications Protocol option for two-way digital communication. This option enables you to configure the analyzer and retrieve its measured data by using:

- A hand-held terminal such as a HART Communicator Model 275 (or other HART<sup>®</sup>-compatible configurator) containing GLI Device Specific Command sets in its non-volatile memory
- An IBM-compatible PC with appropriate HART<sup>®</sup> Field Communications Protocol software



**NOTE:** Any generic hand-held terminal can also communicate with a GLI HART-equipped analyzer, with limited operability, using HART Protocol Universal Commands and/or Common Practice Commands.

The hand-held terminal or PC must be connected to the analyzer 4-20 mA analog Output 1 signal anywhere along the circuit wiring. See subsections 8.3 or 8.4 for more details.

#### HART Information Reference Listings

To obtain complete information on the HART Field Communications Protocol, contact:

HART Communication Foundation  
9390 Research Blvd, Suite II-250  
Austin, Texas 78759 USA

Telephone: [512] 794-0369  
Fax: [512] 794-8893  
Website: [www.hartcomm.org](http://www.hartcomm.org)

For information on the HART Communicator Model 275, contact:

Fisher-Rosemount Systems  
12000 Portland Avenue South  
Burnsville, Minnesota 55337-1535 USA

Headquarters: [612] 895-2000  
Service: [800] 654-7768  
Fax: [612] 895-2244

## 8.2 Analyzer Operating Modes for HART Network

HART enables simultaneous analog and digital communication. The analyzer can be operated in a SINGLE MODE or MULTI-DROP mode on a HART network. An analyzer switch setting selects the mode.

When the analyzer is set to operate in the SINGLE (Point-to-Point) MODE, as set by the factory, HART preserves the integrity of the 4-20 mA analog Output 1 signal for normal use while enabling two-way digital communication between a single analyzer and querying device(s). The analog signal represents the measured process value. The digital signal, encoded onto the analog signal, can be used to:

- Perform all available analyzer functions (presently, only when using a HART Communicator Model 275.)
- Calibrate, configure and acquire all analyzer settings, and retrieve analog output values and measured process value(s).
- Assign device preferences such as a tag, descriptor, message, and date field (for example, to show last calibration date).
- Acquire device information such as analyzer model number, identification number, distributor, etc.
- Acquire HART information including polling address and number of required preambles.

Your HART-equipped “smart” GLI analyzer can also be selected to operate in an all-digital MULTI-DROP mode. This enables you to connect multiple analyzers -- all set for MULTI-DROP operating mode -- to the querying device(s) using a common 4-20 mA output cable, creating an efficient multi-analyzer two-way digital communications network.



**NOTE:** *In the MULTI-DROP mode, the 4-20 mA analog Output 1 signal of each analyzer becomes dedicated only for network use and cannot be used as a normal output.*

Set for either SINGLE MODE or MULTI-DROP operation, the GLI analyzer is always a “slave,” responding to commands received from the “master.” The master can be a hand-held terminal or an IBM-compatible computer with HART-capable software (or software including GLI Device Specific Command sets). The GLI analyzer never initiates a command sequence, but always responds to commands from the master. Up to two master devices may be



connected to each HART loop. Typically, the primary master is a management system or a PC, while the secondary master is usually a hand-held terminal.

**NOTE:** All HART-equipped GLI analyzers are supplied with their **SINGLE MODE/MULTI-DROP** switch set to the **SINGLE MODE** position to preserve analog Output 1 for normal use.

To set the analyzer operating mode for the HART network, locate the **SINGLE MODE/MULTI-DROP** switch (Figure 3-2) and set it to the desired mode:

- **SM** (left) position for SINGLE MODE
- **MD** (right) position for MULTI-DROP mode

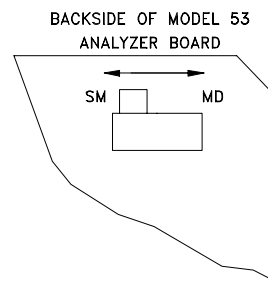

FIGURE 3-2 Location of SINGLE MODE/MULTI-DROP Switch (HART-equipped analyzers only)

### 8.3 SINGLE MODE (Point-to-Point) Wiring Arrangement

When the GLI analyzer is set to operate in the SINGLE (Point-to-Point) MODE on a HART network, the master(s) is intended to communicate with only a single analyzer. Refer to Figure 3-3 and connect all devices, including up to two masters, to the 4-20 mA analog Output 1 signal.

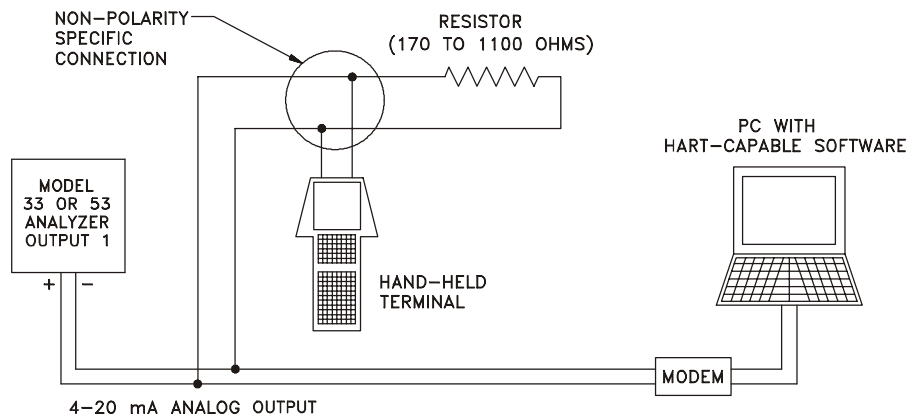

FIGURE 3-3 HART SINGLE MODE (Point-to-Point) Wiring Arrangement (for single analyzer)

## 8.4 MULTI-DROP Wiring Arrangement



When the GLI analyzer is set to operate in the MULTI-DROP mode on a HART network, the master(s) is intended to communicate with multiple analyzers.

**NOTE:** When analyzers are operated in the MULTI-DROP mode, the 4-20 mA analog OUTPUT 1 signal of each analyzer is dedicated only for network use -- not its normal use. (During startup, each analyzer is assigned a non-zero polling address, causing its Output 1 to automatically provide a constant 4 mA signal.) Each analyzer's analog OUTPUT 2, however, remains available for normal use.

1. Make sure the **SINGLE MODE/MULTI-DROP** switch of each analyzer is set to the **MD** (right) position.
2. Refer to Figure 3-4 and connect the 4-20 mA analog Output 1 signal of each analyzer in parallel on one cable, matching polarity as shown.
3. Connect an appropriate-sized power supply in parallel with the analog Output 1 signal, matching polarity as shown.
4. Up to two masters can be connected to the 4-20 mA analog Output 1 signal cable.

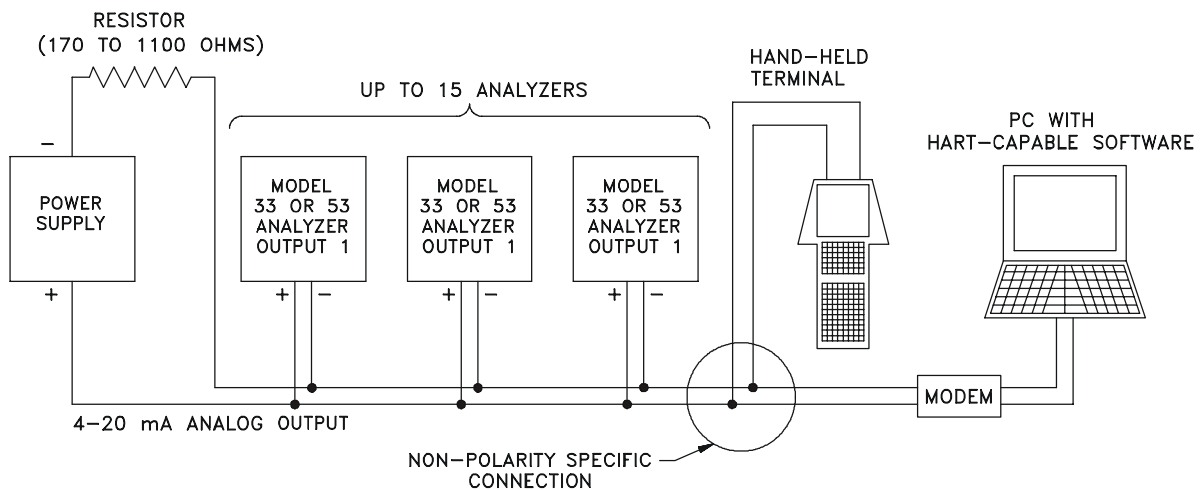

FIGURE 3-4 HART MULTI-DROP Wiring Arrangement (for multiple analyzer network)

## 8.5 HART Preferences Setup

Use a hand-held HART terminal or HART-capable PC to set HART preference information. When using a Model 275 HART Communicator to access preference menus, select the “GLI SETUP” line in the MAIN MENU screen and press the → **key** to reveal this screen:



Use the “HART INFO” submenu to:

- Change the polling address used by the master to identify a device (analyzer).
- View the number of preambles required by a device (analyzer) from the master.

### Changing Polling Address

1. With the “GLI SETUP” top-level menu screen displayed, select the “HART INFO” line and press → **key**.
2. With the “HART INFO” submenu screen displayed, select the “Poll addr” line and press the → **key** to display its related screen.
3. Assign a polling address of “0” for one analyzer in a point-to-point configuration, or 1 through “XX” for two or more analyzers in a multi-drop configuration. Use the alphanumeric keys to directly select the number, or the arrow keys to adjust the number digit by digit.
4. Press the **F4 key** to enter the polling address, and the **F2 key** to send the polling address to the analyzer.

### Viewing Number of Required Preambles

The “Num req preams” information screen shows the number of preambles required by the analyzer from the master.

1. With the “GLI SETUP” top-level menu screen displayed, select the “HART INFO” line and press → **key**.

## 8.6 Device Preferences Setup

2. With the “HART INFO” submenu screen displayed, select the “Num req preams” line and press the **→ key** to display its related information screen.
3. Press the **F4 key** to return to the “HART INFO” submenu screen.

Using a hand-held HART terminal or HART-capable PC, set device (analyzer) preference information.

When using a Model 275 HART Communicator, the “DEVICE INFO” submenu enables you to:

- View the final assembly number of a device.
- View the model number of a device.
- View the manufacturer name of a device.
- Assign a tag associating a device with its installation.
- Assign a descriptor that is associated to a device.
- Assign a message that is associated to a device.
- Assign a user-defined date.
- View the identification number of a device.
- View the revision number(s) of a device.

### Viewing Final Assembly Number

The “Final assembly num” information screen shows the final assembly number of the analyzer.

1. With the “GLI SETUP” top-level menu screen displayed, select “DEVICE INFO” line and press **→ key**.
2. With the “DEVICE INFO” submenu screen displayed, select the “Final assembly num” line and press the **→ key** to display its related information screen.
3. Press the **F4 key** to return to the “DEVICE INFO” submenu screen.

### Viewing Model Number

The “Model” information screen shows the model number of the analyzer.

1. With the “GLI SETUP” top-level menu screen displayed, select “DEVICE INFO” line and press **→ key**.

	<ol style="list-style-type: none"> <li>2. With the “DEVICE INFO” submenu screen displayed, select the “Model Type” line and press the → <b>key</b> to display its related information screen.</li> <li>3. Press the <b>F4 key</b> to return to the “DEVICE INFO” submenu screen.</li> </ol>
Viewing Manufacturer	<p>The “Manufacturer” information screen shows the company that manufactured the analyzer.</p> <ol style="list-style-type: none"> <li>1. With the “GLI SETUP” top-level menu screen displayed, select “DEVICE INFO” line and press → <b>key</b>.</li> <li>2. With the “DEVICE INFO” submenu screen displayed, select the “Manufacturer” line and press the → <b>key</b> to display its related information screen.</li> <li>3. Press the <b>F4 key</b> to return to the “DEVICE INFO” submenu screen.</li> </ol>
Assigning a Tag	<p>A tag is text that associates a device with its installation. Though a tag can be used in any way, there are several recommended uses. For example, the tag can be a unique label for a facility that corresponds to a device label, such as a facility drawing or a control system. The tag can also be used as a type of data link layer address.</p> <ol style="list-style-type: none"> <li>1. With the “GLI SETUP” top-level menu screen displayed, select “DEVICE INFO” line and press → <b>key</b>.</li> <li>2. With the “DEVICE INFO” submenu screen displayed, select the “Tag” line and press the → <b>key</b> to display its related screen.</li> <li>3. Assign a tag. Use the alphanumeric keys to directly create the text, or the arrow keys to adjust the text character by character.</li> <li>4. Press the <b>F4 key</b> to enter the tag, and the <b>F2 key</b> to send the tag to the analyzer.</li> </ol>

## Assigning a Descriptor

A descriptor is text that is associated to a device. It can be used in any imaginable way.

1. With the “GLI SETUP” top-level menu screen displayed, select “DEVICE INFO” line and press → **key**.
2. With the “DEVICE INFO” submenu screen displayed, select the “Descriptor” line and press the → **key** to display its related screen.
3. Assign a descriptor. Use the alphanumeric keys to directly create the text, or the arrow keys to adjust the text character by character.
4. Press the **F4 key** to enter the descriptor, and the **F2 key** to send the descriptor to the analyzer.

## Assigning a Message

A message is text that is associated to a device. It can be used in any imaginable way.

1. With the “GLI SETUP” top-level menu screen displayed, select “DEVICE INFO” line and press → **key**.
2. With the “DEVICE INFO” submenu screen displayed, select the “Message” line and press the → **key** to display its related screen.
3. Assign a message. Use the alphanumeric keys to directly create the text, or the arrow keys to adjust the text character by character.
4. Press the **F4 key** to enter the message, and the **F2 key** to send the message to the analyzer.

Assigning  
User-defined Date

The “Date” information screen shows a user-defined date that can be used in any imaginable way.

1. With the “GLI SETUP” top-level menu screen displayed, select “DEVICE INFO” line and press → **key**.
2. With the “DEVICE INFO” submenu screen displayed, select the “Date” line and press the → **key** to display its related information screen.

### Viewing Identification (ID)

3. Assign a date.
4. Press the **F4 key** to enter the date, and the **F2 key** to send the date to the analyzer.

The “Device id” information screen shows the number that uniquely identifies the analyzer. The ID number cannot be changed by the communicator (master).

1. With the “GLI SETUP” top-level menu screen displayed, select “DEVICE INFO” line and press → **key**.
2. With the “DEVICE INFO” submenu screen displayed, select the “Device id” line and press the → **key** to display its related information screen.
3. Press the **F4 key** to return to the “DEVICE INFO” submenu screen.

### Viewing Revisions

The “DEVICE REVISION” line enables access to three revision level information screens:

- Universal Rev: Revision of the universal device description that the analyzer conforms to.
  - Fld Device Rev: Revision of the analyzer-specific description that the analyzer conforms to.
  - Software Rev: Revision of the software (firmware) that is embedded in the analyzer.
1. With the “GLI SETUP” top-level menu screen displayed, select “DEVICE INFO” line and press → **key**.
  2. With the “DEVICE INFO” submenu screen displayed, select the “Device revision” line and press the → **key**.
  3. With the “DEVICE REVISION” sub-submenu screen displayed, select the appropriate line and press → **key** to display its related information screen.
  4. Press the **F4 key** to return to the “DEVICE INFO” submenu screen.

## 8.7 “Master Reset” Function

HART enables you to reset the analyzer to factory-default values using the “GLI SETUP” menu of the master. The execution of this command may take a relatively long time to complete. Consequently, the analyzer cannot respond to other commands until reset is complete.

1. With the “GLI SETUP” top-level menu screen displayed, select “MASTER RESET” line and press → **key**.
2. After the “MASTER RESET” submenu screen appears, select the “Yes” line.
3. Press the **F4 key** to execute master reset and to return to the “GLI SETUP” top-level menu screen.

## 8.8 “Refresh” Function

The “REFRESH” function enables you to initiate HART to re-synchronize the master to the analyzer in case changes made at the analyzer are not reflected by the hand-held terminal.



**NOTE:** *Since HART only performs housekeeping tasks upon initialization, the “REFRESH” function need only be performed once. However, it may be used anytime thereafter to refresh the variables in the master.*

1. With the “MAIN MENU” top-level menu screen displayed, select the “REFRESH” line and press → **key**.
2. A “Please wait...” message will be displayed until the master has finished retrieving variables from the analyzer. Thereafter, the display will be returned to the “MAIN MENU” top-level screen.

## 8.9 Protocol Command Set for PC Programming

The Universal Commands and some Common Practice commands inherent in the HART protocol can be used for limited operability. The Device Specific Command set for all existing GLI analyzers is available on request for creating a full-featured HART-capable program to run on an IBM-compatible PC.

# PART FOUR - SERVICE AND MAINTENANCE

## SECTION 1

### GENERAL INFORMATION

#### 1.1 Inspecting Sensor Cable

If a measurement problem exists and you suspect the sensor cable, inspect it for physical damage. If an interconnect cable is used, disconnect the cable at both ends (sensor and analyzer) and, using an ohmmeter, check its wires for continuity and internal shorts.

#### 1.2 Replacing Fuse(s)

The analyzer is equipped with two board-mounted fuses (type T slow-blow; 5 mm x 20 mm size). Fuse values are shown next to each fuse (Figure 2-3 or 2-4). The fuses protect the 115 and 230 volt line power circuits.

#### WARNING:

**DISCONNECT LINE POWER TO AVOID THE POSSIBILITY OF ELECTRICAL SHOCK.**

1. After disconnecting line power, open the analyzer door and locate the fuses (shown in Figure 2-3 or 2-4).
2. Remove the blown fuse and replace it with a GLI fuse or an equivalent. Refer to PART FIVE -- Spare Parts -- for GLI fuse kit part number.
3. Reconnect line power and close the analyzer door.

#### 1.3 Replacing Relays

The analyzer relays are soldered into a complex, multi-layered circuit board. To avoid the possibility of damaging this board while attempting to replace a relay:

- Simply return the complete analyzer to the GLI Customer Service Dept. or your local factory-authorized service organization for relay replacement.

-- or --

- Replace the complete scaling board assembly containing the relays. Refer to PART FIVE -- Spare Parts -- for the GLI scaling board assembly part number.

## SECTION 2

## PRESERVING MEASUREMENT ACCURACY

## 2.1 Keeping Sensor Clean

To maintain measurement accuracy, periodically clean the sensor. Operating experience will help you determine the intervals between cleanings (days, weeks, or months). Use the recommended cleaning procedure described in the GLI sensor operating manual.

## 2.2 Keeping Analyzer Calibrated



Depending on application circumstances, periodically recalibrate the analyzer to maintain measurement accuracy.

**Maintenance Tip!** Upon startup, frequently check the system until operating experience can determine the optimum time between calibrations that provides acceptable measurement results.

- pH: Calibrate using one of the methods described in PART THREE, Section 5.2.
- ORP: Calibrate using only the method described in PART THREE, Section 5.3.

Calibrating with old, contaminated, or diluted pH buffers may cause measurement errors. **Do not reuse buffers.** Never pour the portion of buffer used for calibration back into the buffer bottle -- always discard it. Note that the pH value of a buffer changes slightly as its temperature changes. (Always refer to the pH value-versus-temperature table on the buffer bottle). Therefore, always allow the temperatures of the sensor and buffer to equalize while calibrating.

## 2.3 Avoiding Electrical Interference



**Recommendation:** Do not run the sensor cable (and interconnect cable, if used) in the same conduit with AC or DC power wiring. Also, connect cable shielding as recommended (PART TWO, Section 3.1, 3.2 or 3.3).

**Maintenance Tip!** Excess cable should not be coiled near motors or other equipment that may generate electrical or magnetic fields. Cut cables to proper length during installation to avoid unnecessary inductive pickup (“electrical noise” may interfere with sensor signal).

## SECTION 3

### TROUBLESHOOTING

#### 3.1 Ground Loops

The analyzer may be affected by a “ground loop” problem (two or more electrically grounded points at different potentials).

#### Symptoms Indicating A Possible Ground Loop

- Analyzer reading is offset from the actual value by a consistent amount, or ....
- Analyzer reading is frozen on one value, or ....
- Analyzer reading is “off scale” (upscale or downscale).

Although the source of a ground loop is difficult to determine, there are several common causes.

#### Common Causes of Ground Loops

- Components, such as recorders or computers, are connected to non-isolated analog outputs.
- Not using shielded cabling or failure to properly connect all cable shields.
- Moisture or corrosion in a junction box.

#### Determining if Ground Loop Exists

The following simple test can help to determine if there is a ground loop:

1. With the pH (or ORP) MEASURE screen displayed, put the sensor in a non-conductive container (plastic or glass) filled with a pH buffer (or ORP reference solution) of known value. Note the analyzer reading for this solution.
2. Connect one end of a wire to a known earth ground, such as the analyzer grounding strip (at bottom of case) or a metal water pipe. Place the other end of this wire into the buffer next to the sensor.
3. Note the analyzer reading now and compare it with the reading taken in step 1. If the reading changed, a ground loop exists.

## Finding Source of Ground Loop



Sometimes the source of a ground loop is easy to find, but it usually takes an organized approach to isolate the problem.

**Troubleshooting Tip!** Use a systematic troubleshooting method. If possible, start by grounding all shields and electrical grounds at one stable point. One at a time, turn off all pumps, motors and switches that are in contact with the process. Each time you do this, check if the ground loop still exists. Since the process media being measured is electrically conductive, the source of the ground loop may not be readily apparent.

## 3.2 Isolating Measuring System Problem

### Checking Electrical Connections

When experiencing problems, try to determine the primary measurement system component causing the problem (sensor, analyzer or interconnect cable, if used).

1. Verify that line power exists at the appropriate analyzer TB3 terminals.
2. Check all analyzer cable connections to ensure they are properly connected.

### Verifying Sensor Operation

To verify sensor operation, refer to the procedure in the troubleshooting section of the sensor operating manual.

### Verifying Analyzer Operation

#### **WARNING:**

**DISCONNECT LINE POWER TO AVOID THE POSSIBILITY OF ELECTRICAL SHOCK.**

1. After disconnecting line power from the analyzer, disconnect the sensor.
2. Depending on the type of sensor, refer to the appropriate category below and follow the steps to simulate a pH (or ORP) input signal and a temperature signal:

For GLI Differential Technique Sensor

- A. Connect a millivolt generator (or a jumper, if generator is not available) between Terminal 20

(green) and Terminal 22 (red) on TB1, with the (+) lead wire on Terminal 22.

- B. Connect a 1% tolerance, 301 ohm resistor between Terminal 14 (black) and Terminal 16 (yellow) on TB1.
- C. Make sure the analyzer is configured for a 300 ohm NTC temperature element (PART THREE, Section 4.2, "Select TEMP ELEMENT Type").

For Conventional Combination Electrode

- A. Keep the jumper connected. For analyzers with:
  - "B" prefix serial numbers, jumper is between Terminals 18 and 20 on TB1.
  - "A" or no letter prefix serial numbers, jumper is between Terminals 18 and 19 on TB1.
- B. Connect a millivolt generator (or a jumper, if generator is not available) between Terminal 20 (reference) and Terminal 22 (active) on TB1, with the (+) lead on Terminal 22.
- C. Connect a 1% tolerance, 1000 ohm resistor between Terminal 14 and Terminal 15 on TB1.
- D. Make sure the analyzer is configured for a Pt 1000 temperature element (PART THREE, Section 4.2, "Select TEMP ELEMENT Type").

3. Reconnect line power to the analyzer.

**WARNING:**  
**LINE POWER IS PRESENT. BE CAREFUL TO AVOID ELECTRICAL SHOCK.**

4. Set millivolt generator to provide each of the following outputs, checking the analyzer MEASURE screen each time for these corresponding pH (or mV) readings:

Generator Output	Corresponding Analyzer Reading	
	For pH	For ORP
Zero mV	7 pH (approximately)	0 mV
(-)175 mV	10 pH (approximately)	(-)175 mV
(+)175 mV	4 pH (approximately)	(+)175 mV

When Using Jumper Only (not generator)

- - - -	7 pH (approximately)	0 mV
---------	----------------------	------

Verifying Interconnect  
Cable Integrity

5. Change the MEASURE screen to show temperature:
  - For a GLI Differential Technique sensor, the temperature value should be approximately “25°C.”
  - For a conventional combination electrode, the temperature value should be approximately “0°C.”

If these readings are achieved, the analyzer is operating properly, but the sensor or interconnect cable (if used) may be inoperative. If you cannot get these readings, the analyzer is probably inoperative.

**WARNING:**

**LINE POWER IS PRESENT. BE CAREFUL TO AVOID ELECTRICAL SHOCK.**

1. After disconnecting line power, remove the millivolt generator and temperature simulation resistor. (When using a GLI Differential Technique sensor, also remove the jumper from the analyzer TB1 terminals.)
2. Reconnect the sensor directly to the analyzer (purposely bypassing the interconnect cable and junction box, if used).
3. Reconnect line power to the analyzer.

**WARNING:**

**LINE POWER IS PRESENT. BE CAREFUL TO AVOID ELECTRICAL SHOCK.**

4. Use a two-point method to calibrate the analyzer. (For ORP measurement, use only the “1 POINT SAMPLE” method described in PART THREE, Section 5.3.) If calibration was:
  - **Successful:** The analyzer and sensor are operating properly, but the interconnect cable is probably faulty.
  - **Unsuccessful:** The sensor is probably inoperative.

# SECTION 4

## ANALYZER REPAIR/RETURN

### 4.1 Customer Assistance

If you need spare parts, assistance in troubleshooting, or repair service, please contact your local GLI representative, or the GLI Customer Service Department at:

GLI International, Inc.	Phone: [800] 543-8907
9020 West Dean Road	Fax: [414] 355-8346
Milwaukee, WI 53224	E-mail: info@gliint.com

— GLI CUSTOMER SERVICE DEPARTMENT HOURS —

	Eastern Std. Time	Central Std. Time	Mountain Std. Time	Pacific Std. Time
Monday through Thursday	8:30 a.m. to 5:30 p.m.	7:30 a.m. to 4:30 p.m.	6:30 a.m. to 3:30 p.m.	5:30 a.m. to 2:30 p.m.
Friday	8:30 a.m. to 4:00 p.m.	7:30 a.m. to 3:00 p.m.	6:30 a.m. to 2:00 p.m.	5:30 a.m. to 1:00 p.m.

### 4.2 Repair/Return Policy

Call the GLI Customer Service Dept. before returning an analyzer for repair. Many problems can be diagnosed and resolved over the telephone. GLI will issue a Return Material Authorization (RMA) number if it is necessary that the analyzer be returned for repair. **All returned analyzers must be freight prepaid and include:**

1. A clearly written description of the malfunction.
2. Name of person to contact and the phone number where they can be reached.
3. Proper return address to ship analyzer back. Include preferred shipping method (UPS, Federal Express, etc.) if applicable.
4. A purchase order if analyzer is out of warranty to cover costs of repair.



**NOTE:** *If the analyzer is damaged during return shipment because of inadequate packaging, the customer is responsible for any resulting repair costs. (Recommendation: Use the original GLI shipping carton or an equivalent.)*

*Also, GLI will not accept analyzers returned for repair or replacement unless they are thoroughly cleaned and all process material is removed.*

# PART FIVE - SPARE PARTS AND ACCESSORIES

	Description	Part Number
Analyzers with "B" Prefix Serial Numbers	Complete Door Assembly:	
	Without HART option .....	P53A2010-003
	With HART option .....	P53A2010-004
	Power Supply/Scaling Board Assembly .....	P53A2020-001
	Ribbon Interconnect Cable .....	1000A3355-001
Analyzers with "A" Prefix Serial Numbers	Complete Door Assembly .....	P53G1010-201
	Power Supply/Scaling Board Assembly .....	P53G1040-101
	Ribbon Interconnect Cable .....	1000A3334-001
Analyzers with No Letter Prefix Serial Numbers	Complete Door Assembly .....	P53G1010-201
	Power Supply/Scaling Board Assembly .....	P53G1040-101
	Ribbon Interconnect Cable .....	4W001

**The following parts are common to all  
P53 Analyzers regardless of serial number prefix:**

Fuse Kit (one 80 mA fuse and one 100 mA fuse per package).....	1000G3315-101
Mounting Hardware Kit .....	1000G3228-101
Analyzer Sun Shield .....	1000G3088-001