



## **SAFETY INSTRUCTIONS**



**Before using any Fluid Metering, Inc. product read the following safety instructions as well as specific product specifications and operating instructions.**



**Warning! Fire, electrical shock or explosion may occur if used near combustibles explosive atmosphere, corrosive air wet environment or submerged in fluid.**

- Turn off the electrical power before checking pump for any problems.
- Connect motor, speed controllers, or any other electrical devices based on Fluid Metering Inc. specifications. Any unauthorized work performed on the product by the purchaser or by third parties can impair product functionality and thereby relieves Fluid Metering, Inc. of all warranty claims or liability for any misuse that will cause damage to product and /or injury to the individual.
- Power cables and leads should not be bent, pulled or inserted by excessive force. Otherwise there is a threat of electrical shock or fire.
- Replace any-in- line fuses only with fuse rating as specified by Fluid Metering, Inc.
- When pump/drive is under operation, never point discharge tubing into face or touch any rotating components of pump.
- In a power down thermal overload cut-in condition, unplug or turn off power to pump. Always allow a cool down period before restarting: otherwise, injury or damage may occur.
- For 30 seconds after power is removed from pump/drive: do not touch any output terminals. Electrical shock may occur because of residual voltage.



**Caution! Fire, electrical shock, injury and damage may occur if not used in accordance with Fluid Metering, Inc. specifications and operation instructions.**

- Do not put wet fingers into power outlet of unit.
- Do not operate with wet hands
- Do not operate drive assemblies that require a hard mount (to be bolted down) unless they are mounted per Fluid Metering, Inc. specifications, if not injury may occur and/or damage to unit.
- Do not touch any rotating pump or motor components: injury may occur.
- Do not run pump dry, unless designed for that service.
- Running dry is harmful to the pump, and will cause excessive heating due to internal friction.
- Check pump rotation and inlet/outlet pump port orientation before connecting power to pump. If not injury may occur.
- When pulling out cords from outlets do not pull cord, grasp plug to prevent plug damage or electrical shock.
- Fluid Metering, Inc. Drive Motors become **HOT** and can cause a burn. **DO NOT TOUCH!**

## General Instructions

Congratulations! You are about to install the newest technology from FMI, designed specifically for industrial dispense applications, where long-term trouble-free performance is expected. If you have any questions during any stage of your installation please don't hesitate to give us a call. Our technical staff is ready with answers. Call us at 1-800-223-3388. LET'S GET STARTED!

Your controller is initially set to provide one dispense per signal at 320 strokes per minute.\* Dispense signal, other speed settings, and dispense values are easily set by following the detailed instructions on the following pages. \* Best speed for most dispense applications.

Connect cable from CONNECTOR P1 on the housing to your PLC or controller and power supply as per the following pin connections. NOTE: Not all the available functions may be suitable for your application; therefore some wires may not need to be connected.

The following connections are made through the 6' cable provided. It has a nine-pin Amp Series 1, Circular Connector, shell size 13, arrangement 13-9, standard sex (Plug/Socket). This connector is P1 on Figure 1.

1. Power positive (+24-30VDC Max) Fused 2.5 Amp Time Lag	Pin #1	Red
2. Power Ground	Pin #2	Black
3. Flag Verify, (+Side Sinking Open Collector) 12-30 V Max @ 20mA max	Pin #3	Blue
4. Safety Ground	Pin #4	Green/Yellow
5. Flag Verify, Return, Emitter	Pin #5	Orange
6. Start (+Side Sinking Opto-Isolator LED Input) 12-30 V Max @ 20mA	Pin #6	Yellow
7. Start Return - Signal Common	Pin #7	White
8. Analog Volts Input, 0.1-5.0 V Max (Optional)	Pin #8	Brown
9. Dispense/Run (+Side Sinking Opto-Isolator Input) 12-30 V Max @ 20mA	Pin #9	Violet

FMI provides a 6' (2 meters) shielded 9-pin hook up cable, Part No. 200204.

**FIGURE 1**

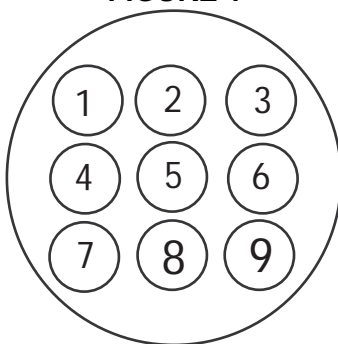

**P1 INPUT CONNETOR VIEWED  
 FROM OUT SIDE BOX  
 FIGURE 1**

**1.0 Description**

The IDS Industrial Dispenser has a stepper motor and a self-contained step motor controller specifically designed for use with Fluid Metering valveless pumps. It contains its own step output drivers and can be set to several run modes utilizing either internal or external controls. This system is designed for maximum performance in all industrial situations. If you have any questions at all, please don't hesitate to call our technical hot line at 1-800-223-3388.

**1.1 Features**

- Pre-set Run Modes.
- Multiple Control Methods: PLC \*, Relay, 0-5 VDC, or manually by internal switches.
- Dispense Run, Purge, etc.
- Variable speeds.
- Verification of dispense cycle and rotation.
- Opto-isolated inputs.
- Auto-Current reduction, when not in a running mode.
- Internally fused at 2.5 A via a plug-in fuse socket.
- Automatic over temperature shutdown of drive current output if driver devices reach 70 °C internal temperatures. Note: This does not prevent motor overheating!
- Rugged 304 Stainless Steel, NEMA type 12, IP 65 enclosure.

\*Typical compatible PLC's are: Texas instruments Ti 305, SIMATIC, GE Fanuc OCS stations, Cruzet Type RPX and DIAL 5, DIAL 10 systems, IDEC's series of Micro 3 or Micro 3 C and PLC Direct DL105 through DL 405. PLCs require opto-isolated or relay outputs for start, run or dispense functions and an opto-isolated current loop input.

**2.0 Run Modes**

The step motor controller board housed in the IDS can drive pumps in any of the following modes by changing switches on the Switchboard 200293 as shown below.

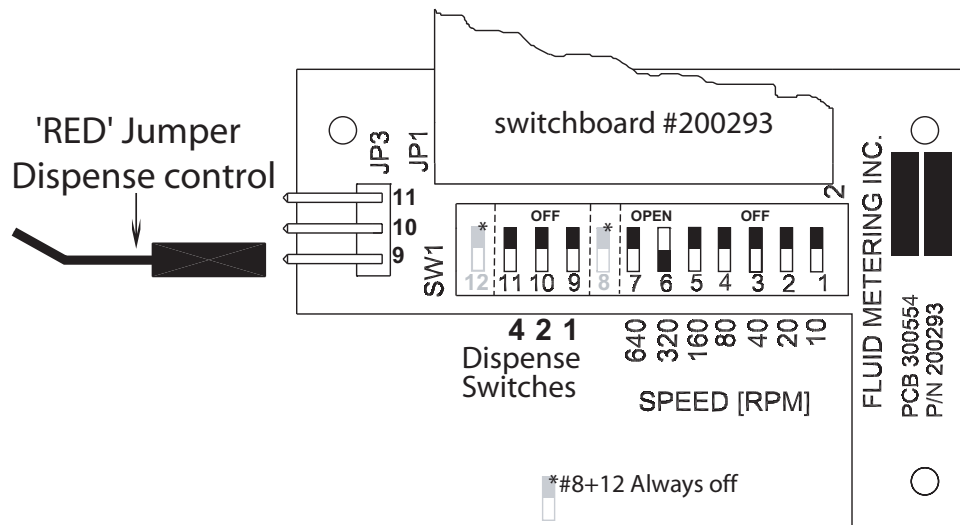

ENCLOSURE FASTENERS MUST BE TORQUED TO 6 INCH POUNDS ± 10% TO ASSURE PROPER SEALING.



### 2.1 Dispense Mode:

The IDS comes factory set for one dispense revolution\*\* per signal at 320 rpm\* Dispense start actuation is handled by pins 6 (YELLOW) and return pin 7 (WHITE) of the external connector, P1. The minimum signal input time that this function can respond to is 20 milliseconds (0.020 sec) to a maximum of 100 milliseconds, or less than the time it takes to make one revolution.

\*.You can, have up to seven shots per signal if desired. The number of shots per Start signal is set by switches 9, 10, 11 and Red Jumper on Switchboard # 200293. See Matrix below (Figure 2A) \*\* ( FMI has determined that 350 RPM is best speed for a single revolution dispense, this may vary depending on the hydraulics of your system.)

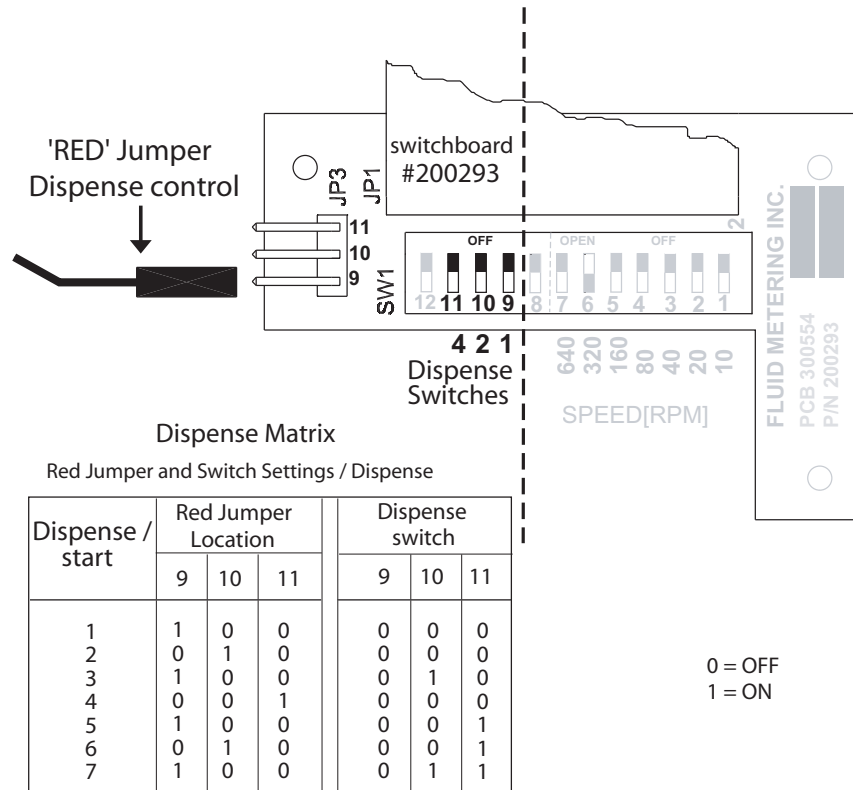

Fig 2A



**2.2 RUN / PURGE MODE**

A current of 6 to 20mA must be supplied continuously throughout the signal current input at P1, Pin 9 (VIOLET) to keep the dispenser in a **continuous run** mode. **THE ABSENCE OF THIS SIGNAL WILL HOLD THE PUMP IN A DISPENSE MODE ONLY.** Run / Purge Actuation is handled by Pin 9 (VIOLET) (+ side sinking) and 7 (WHITE) (return) on the input connector P1 (see Figure 1, Page 1), by providing a current of 6 to 20mA through a switch closure, PLC, Relay, Mechanical Timer/Counter or transistor output

**2.3 Timed/Count Dispense/Continuous Run Mode**

To activate this mode for a timed dispense system, the closing of dispense switch 9 is done externally using a control signal current input at P1 Pin 9 (VIOLET) for one dispense per signal. The pump will begin running when this connection is closed, and rotation will cease when the control current is turned off from Pin 9 of P1. **The current must be provided through a resistor** (the typical values are shown on Table 2 below) from a counter or timer that can control a SPST relay or switch closure. External counters and PLCs can use the **VERIFY SIGNAL OUTPUT** (P1 Pin 3 (BLUE), verify return common Pin 5 (ORANGE)) to sense and count each revolution pulse. If no PLC is used, a standard industrial counter such as OMRON H7CR can be set to count up to 9999999 revolutions, and then stop.

**Table 2**

VOLTS	OPTO-OUTPUT OHMS	TRANSISTOR OUTPUT OHMS	RELAY OUTPUT, OHMS
6	220	220	270
9	390	390	470
12	620	620	680
15	820	820	820
18	1000	1000	1000
24	1300	1300	1500
28	1600	1600	1800
30	2000	2000	2000

**NOTE:** These are the closest values of current limiting 5%, ¼ watt resistors for the applied voltages. Voltage control sources **must** have series resistors as shown in Table above, to limit control signal currents to the input opto-isolators, Pins 3, 6, 9, on P1.



## **2.4 External Control 0-5 VDC - Voltage Following Input Mode**

In order for the stepper controller board to recognize and accept a 0-5 VDC control input, all **speed switches 1-7** (Switchboard #200293, Figure 2,) **must be turned off**. The board will **not** respond to a voltage input unless all speed switches are off. Once off, a DC voltage (5.0 volts max.) signal may be applied via the input cable (P1) Pin 8 (RED) (+ voltage) and Pin 7 common returns. A variation of that voltage will linearly vary the motor speed. Maximum speed using a 0-5 volt DC input signal is limited to  $\approx 1000$  rpm. (The smallest increment is about 10 rpm.)

## **2.5 Continuous (Constant Run) Mode**

By turning off the Dispense switches 9, 10, 11 on the Switchboard, and having a current signal at P1 Pin 9 (VIOLET), will allow the motor run at a continuous pre- set speed. This condition is useful for priming the system.

Speed while factory set at 320rpm may be changed according to 5.0

## **3.0 Motor Direction**

Factory preset to be **CLOCKWISE** looking into the pump head. Suction is on the **RIGHT**, discharge on the **LEFT**, when the pump head is facing you.

## **4.0 Power Supply requirements**

***A single 24 VDC power supply delivering 2.0 amps (minimum) of current is required for driving the IDS 2000A. Connect positive (+) to P1 Pin 1 (RED) and negative (-) to P1 Pin 2 (BLACK).*** An additional power supply may be needed to provide input currents to the control inputs, if they are not internally sourced from your controller.



**5.0 Speed switches –Switchboard # 200293**

The SPEED switches 1 -7 are used for changing the speed settings.

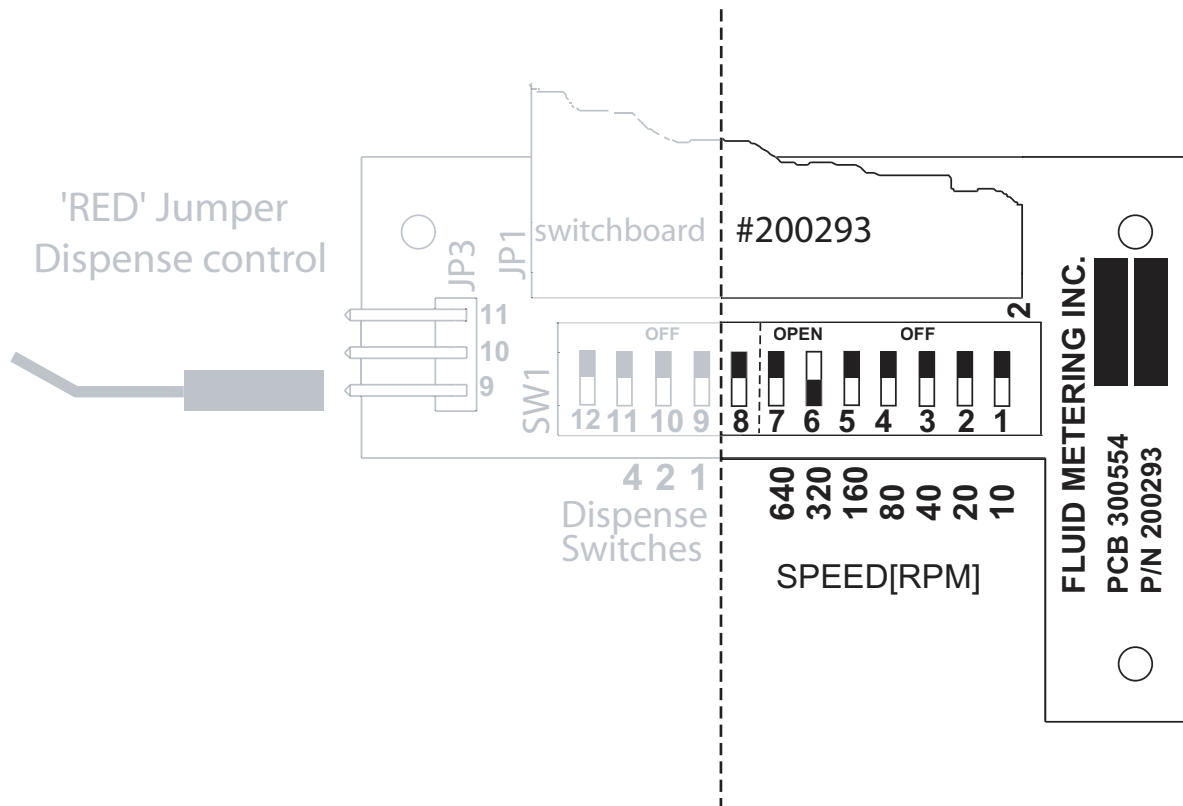

**Fig 2B**

The switches are set up as a binary system. This means that multiple switches will add their values together. For example, to set the motor to run at 500 rpm you must turn on switch 6, 5 and 2 (320+160+20 = 500 rpm). The switches can give a maximum speed of 1000rpm.

The controller will run at a constant pre-set speed via switches 1 through 7, until control current to P1 Pin 9 (VIOLET).is removed. When the current is removed the unit returns to “one cycle per start signal”. At the first cycle of the dispense mode the pump will “home” itself to the proper starting point. All following dispense cycles will then home to the proper start position.



# FLUID METERING, INC.

5 AERIAL WAY, SUITE 500, SYOSSET, NY 11791  
800-223-3388 • 516-922-6050 • FAX 516-624-8261  
http://www.fmipump.com

# IDS INDUSTRIAL DISPENSER INSTRUCTIONS

ISO9001

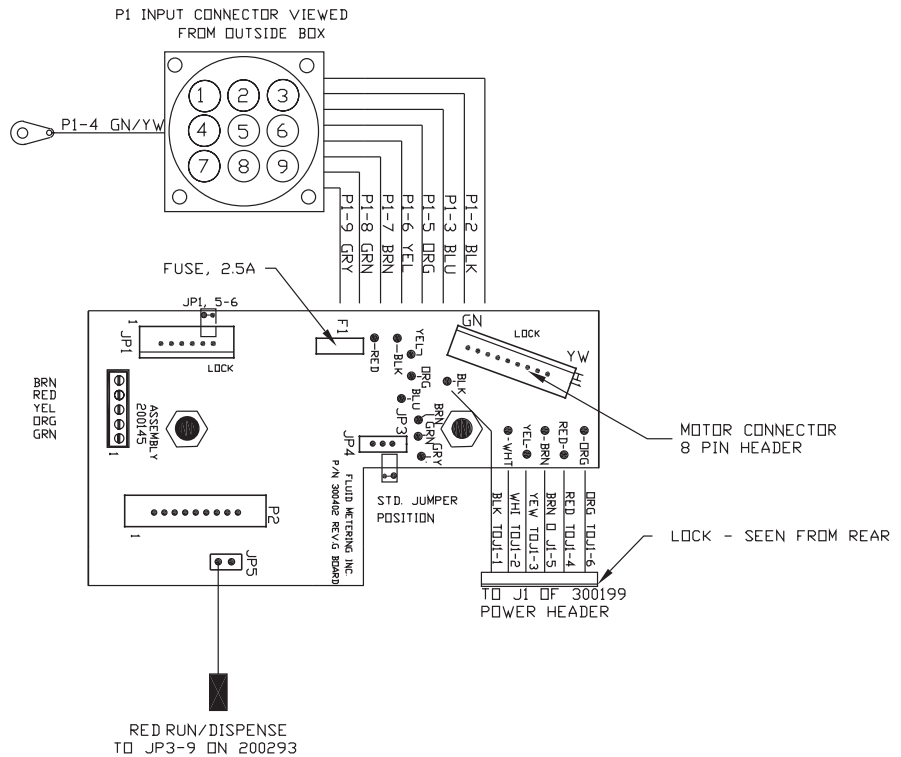
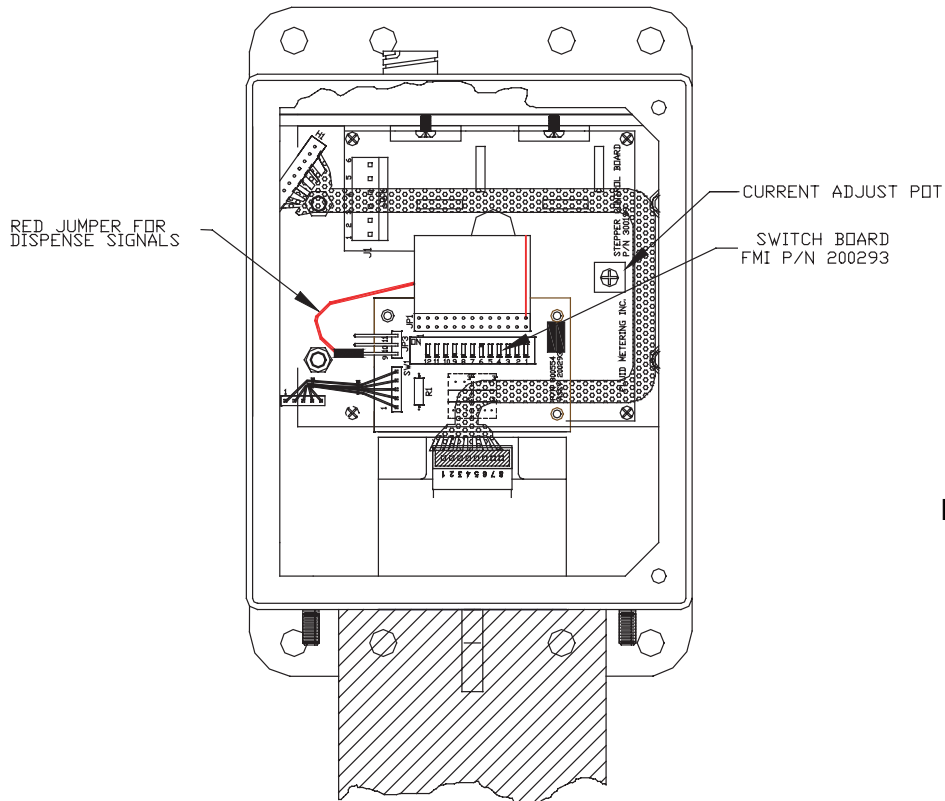

FIGURE 4 (200145)



If a **TIMED/COUNTED** dispense is run, the pump will **stop at the point of signal turn off**. It will **NOT** continue to complete the interrupted revolution. The pump will only complete the cycle if a single Start command is given or as part of the next TIMED /COUNTED cycle.

**6.0 Dispense / Flow Rates**

To avoid cavitation at maximum speed use maximum internal diameter tubing at the suction side. Cavitation produces noise and inaccuracies of flow.

See 7.0 Calibration

IDS FLOW INFORMATION				
PISTON SIZE	MAX mL PER STROKE	RPM MAXIMUM	FLOW RANGE mL/MIN	PRESSURE (PSIG) MAX
Q0 (1/8)	0.08	1000	0 - 80	60
Q1 (1/4)	0.32	1000	0 - 320	60
Q2 (3/8)	0.72	900	0 - 650	15
Q3 (1/2)	1.28	800	0 - 1000	5
Interchangeable pumphead modules permit this industrial dispenser to be operated in any of four flow rate ranges.				
RH00 (1/8)	0.025	1000	0 - 25	100
RH0 (3/16)	0.050	1000	0 - 50	100
RH1 (1/4)	0.100	1000	0 - 100	100
Interchangeable pumphead modules permit this industrial dispenser to be operated in any of three flow rate ranges.				

## 7.0 Calibration and Displacement

Your IDS comes factory calibrated to maximum displacement of the installed pumphead unless ordered with specific displacement and calibration. Recalibration and changes of displacement are relatively easy.

### 7.1 Calibration for Dispensing

FMI calibrates by weighing 3 or more dispenses on an analytical balance. It then finds the average. The pumphead displacement is then adjusted as required up or down accordingly. See Fig

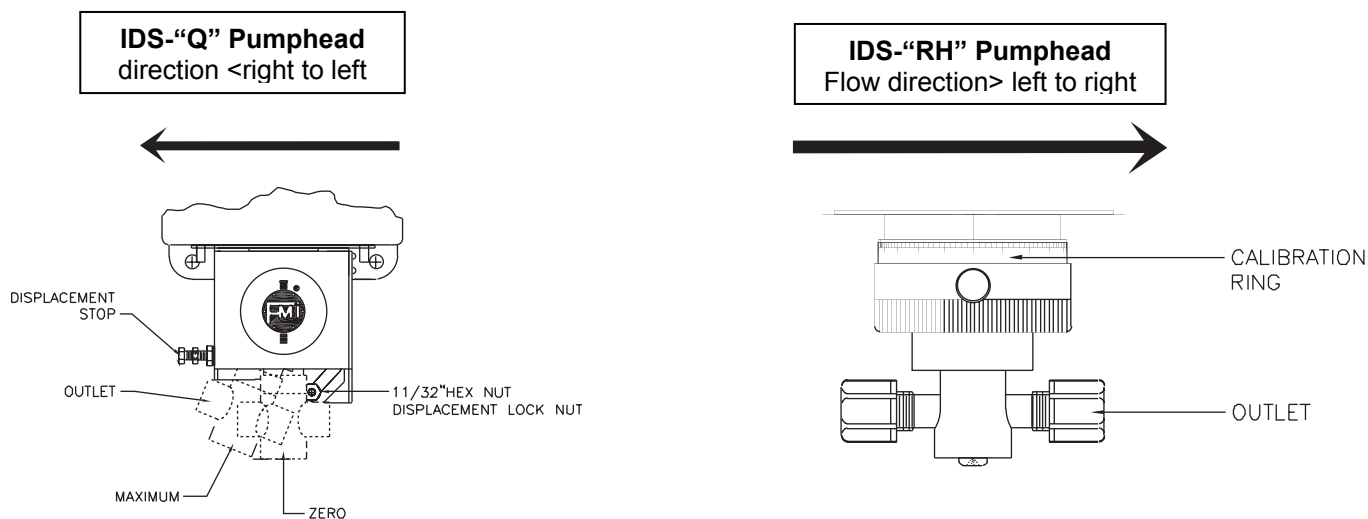

Displacement is adjusted by changing Angle of pumphead. Loosen 11/32 hex nut and move pumphead "left to increase" and "right to decrease". Now recalibrate. Lock hex nut set and lock Displacement adjust stop screw.

The Knurled ADJUSTMENT NUT on the pumphead controls stroke to stroke Piston displacement. Turning clockwise to zero stops displacement. Turning the ADJUSTMENT-NUT counterclockwise four and one half turns from zero (450 on scale) (fig.5) causes maximum pump reciprocation, e.g., 50  $\mu$ l per stroke for the H-0 or 100  $\mu$  for H-1 unit. Thus each 1-1/8 turn (112.5 on scale) of the ADJUSTMENT NUT Represents 25% of maximum (12.5 $\mu$ l for H-0 and 25 $\mu$ l for H-1) and each graduation on the ring represents an **adjustment** of 1/450<sup>th</sup> of maximum (0.111  $\mu$ l for H-0, 0.222  $\mu$ l for H-1).

FIXED CALIBRATION LINE

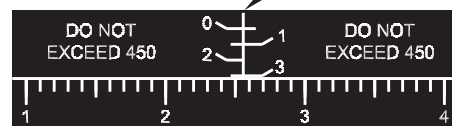

CALIBRATION RING



**FLUID METERING, INC.**  
 5 AERIAL WAY, SUITE 500, SYOSSET, NY 11791  
 800-223-3388 • 516-922-6050 • FAX 516-624-8261  
 http://www.fmipump.com

**IDS INDUSTRIAL DISPENSER  
 INSTRUCTIONS  
 ISO9001**

NOTE : FMI TO BE NOTIFIED IN WRITING PRIOR TO ANY CHANGES IN MATERIALS, PROCESSES OR CONSTRUCTION.

REVISIONS				
SYM	DESCRIPTION	BY	DATE	APVD
A	NEW PART	A.N.S.	8/16/02	C.℔.

**INSTALLATION INSTRUCTIONS FOR MOUNTING  
 THERMAL PAD, FMI P/N 300598**

1. CLEAN THE MACHINE MOUNTING SURFACE OF ALL OILS AND PARTICLES. BE SURE THE SURFACE IS FREE OF RAISED GOUGES OR BURRS.
2. CAREFULLY REMOVE THE BLUE SHEET FROM THE PAD.
3. THE EXPOSED WHITE SURFACE IS "TACKY" AND WILL STICK TO THE BACK OF THE PUMP ENCLOSURE.
4. ALIGN THE HOLES IN THE PAD AND MOUNTING SURFACE.
5. PRESS THE PAD INTO PLACE.
6. REMOVE ANY AIR BULGES FROM UNDER THE PAD.
7. BOLT THE DISPENSER IN PLACE.
8. REPLACE WITH A NEW 300598 PAD IF THE UNIT IS REMOVED.

**FMI P/N 700023**

TOLERANCES  
 UNLESS OTHERWISE SPECIFIED  
 .XX = ±0.10  
 .XXX = ±0.005  
 ANG = ±1°  
**DO NOT SCALE**

SURFACE FINISH 63



*Fluid Metering Inc.*  
 5 Aerial Way, Suite 500  
 Syosset, NY 11791

Chemical Metering Pumps

NOTICE TO PERSONS RECEIVING THIS DRAWING  
 FLUID METERING INC. CLAIMS PROPRIETARY RIGHTS IN THE MATERIAL DISCLOSED HEREON. THIS DRAWING IS LOANED IN CONFIDENCE FOR INFORMATIONAL PURPOSES ONLY AND MAY NOT BE REPRODUCED, DISTRIBUTED, SOLD, RELENT, OR USED TO MANUFACTURE ANYTHING SHOWN HEREON WITHOUT DIRECT PRIOR WRITTEN PERMISSION FROM FLUID METERING, INC. TO THE USER. THIS DRAWING IS LOANED FOR MUTUAL ASSISTANCE AND REMAINS THE PROPERTY OF FLUID METERING, INC. IT IS SUBJECT TO RECALL AT ANY TIME.

IDS2000	MAT'L	N/A	TITLE	
IDS2000GM	FINISH	N/A	THERMAL PAD MOUNTING LABEL	
	DRAWN BY	A. ℔. ℔.	DATE	8/16/02
	CHECKED BY	℔. ℔. ℔.	DATE	8/16/02
	APP'VD BY	C. ℔.	DATE	8/16/02
	ORIG. DWG BY	A. ℔. ℔.	DATE	8/16/02
USED ON	FILENAME	700023 REV A.DWG	SCALE	DWG NO.
			NONE	700023
				REV A

Sht 1 of 1



**FLUID METERING, INC.**  
 5 AERIAL WAY, SUITE 500, SYOSSET, NY 11791  
 800-223-3388 • 516-922-6050 • FAX 516-624-8261  
 http://www.fmipump.com

**IDS INDUSTRIAL DISPENSER  
 INSTRUCTIONS**  
 ISO9001

NOTE: FMI TO BE NOTIFIED IN WRITING PRIOR TO ANY CHANGES IN MATERIALS, PROCESSES OR CONSTRUCTION.

REVISIONS				
SYM	DESCRIPTION	BY	DATE	APVD
F	REVISED PER ECO#1785	W.A.	3/23/04	C.Y.

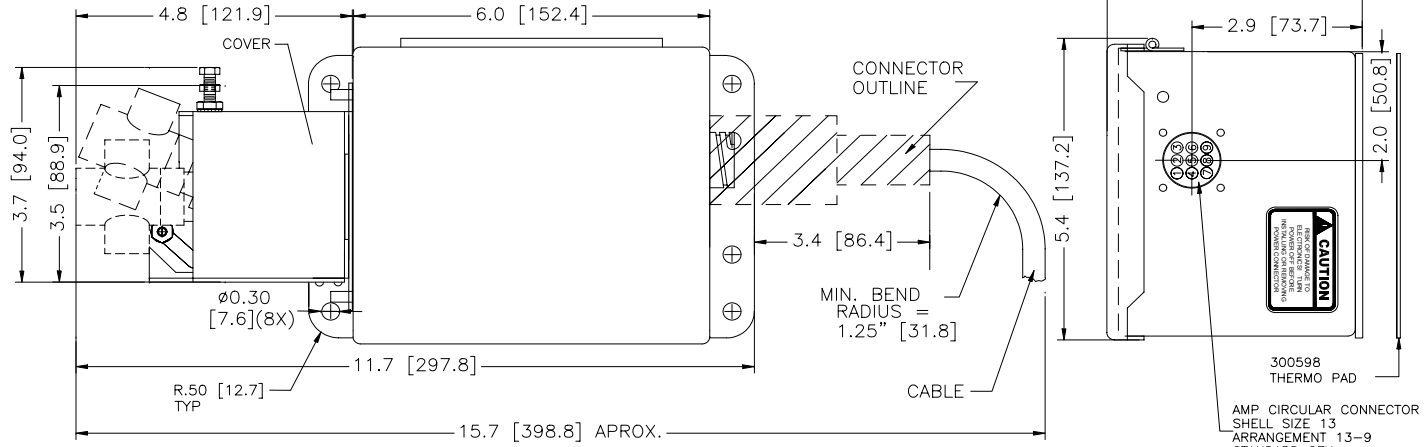

**GENERAL SPECIFICATIONS:**

**OPERATING CONDITIONS:**

AMBIENT TEMPERATURE: 41°F - 104°F [5°C - 40°C] IN STILL AIR. MOUNTED VERTICALLY, WITH AT LEAST 1 INCH OF CLEAR AIR SPACE ON ALL SIDES. MOUNTING MAY BE BY 1 INCH WIDE BARS OR CHANNELS. FOR HIGHER TEMPERATURE AMBIENT, ADDITIONAL HEAT SINKS AND FORCED AIR WILL BE REQUIRED TO KEEP THE HOUSING OUTSIDE TEMPERATURE TO A MAXIMUM OF 125°F [52°C] ON ANY SURFACE.

RELATIVE HUMIDITY; 30% TO 80% NON-CONDENSING.

ATMOSPHERIC PRESSURE; 10.5 PSI [700 MILLIBARS] TO 15.4 PSI [1060 MILLIBARS].

**NON-OPERATIONAL CONDITIONS:**

AMBIENT TEMPERATURE; 0°F [-18°C] TO 158°F [70°C].

RELATIVE HUMIDITY; 30% TO 85% NON-CONDENSING.

ATMOSPHERIC PRESSURE; 7.5 PSI [500 MILLIBARS] TO 15.4 PSI [1060 MILLIBARS].

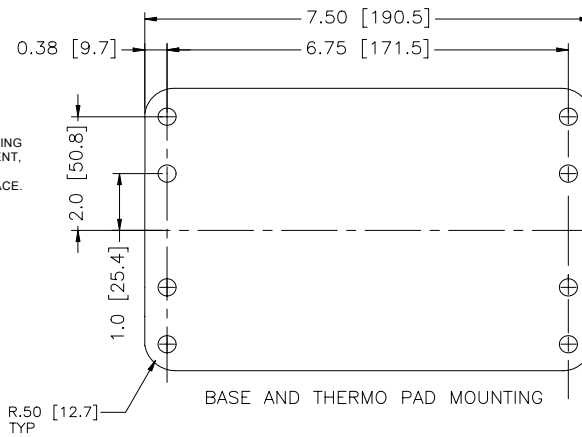

NOTICE TO PERSONS RECEIVING THIS DRAWING  
 FLUID METERING INC. CLAIMS PROPRIETARY RIGHTS IN THE MATERIAL DISCLOSED HEREON. THIS DRAWING IS LOANED IN CONFIDENCE FOR INFORMATIONAL PURPOSES ONLY AND MAY NOT BE REPRODUCED, DISTRIBUTED, SOLD, RENTED, OR USED TO MANUFACTURE ANYTHING SHOWN HEREON WITHOUT EXPRESS WRITTEN PERMISSION FROM FLUID METERING, INC. TO THE USER. THE DRAWING IS LOANED FOR WRITING ASSISTANCE AND REMAINS THE PROPERTY OF FLUID METERING, INC. IT IS SUBJECT TO RECALL AT ANY TIME.

FMI P/N IDS2000A / IDS2000AGM

TOLERANCES X = ±.015  
 UNLESS OTHERWISE SPECIFIED XX = ±.010  
 DO NOT SURFACE FINISH  
 SCALE FINISH

**Fluid Metering Inc.**  
 5 Aerial Way, Suite 500  
 Syosset, NY 11791

MATERIAL		SEE NOTES		TITLE	
FINISH	SEE NOTES	DATE	3/23/04	<b>OUTLINE DRAWING</b> IDSA SERIES ENCLOSURE	
DRAWN BY	W.A.	DATE	3/23/04		
CREATED BY	S.P.S.	DATE	3/23/04		
APPROVED BY	C.M.	DATE	3/23/04		
ORIG. DATE	W.A.	DATE	3/23/98		
FILENAME	600059.DWG	SCALE	NONE	DWG NO.	600059
USED ON				REV	F



**FLUID METERING, INC.**  
 5 AERIAL WAY, SUITE 500, SYOSSET, NY 11791  
 800-223-3388 • 516-922-6050 • FAX 516-624-8261  
 http://www.fmipump.com

**IDS INDUSTRIAL DISPENSER  
 INSTRUCTIONS**

**ISO9001**

NOTE : FMI TO BE NOTIFIED IN WRITING PRIOR TO ANY CHANGES IN MATERIALS, PROCESSES OR CONSTRUCTION.

REVISIONS				
SYM	DESCRIPTION	BY	DATE	APVD
D	30V WAS 20v, NOTE 1 ECO# 1745	W.A.	2/5/04	C. J.

200204 INPUT CABLE ASSEMBLY, (EXTERNAL WIRING)

PIN	COLOR	INPUT CABLE
1	RED	24 V POWER
2	BLACK	24 V COMMON
3	BLUE	FLAG VERIFY, OPEN COLLECTOR
4	GREEN	SAFETY GND
5	ORANGE	FLAG VERIFY, RETURN, EMITTER
6	YELLOW	START SIGNAL, + INPUT
7	WHITE	START RETURN-SIGNAL COMMON
8	BROWN	ANALOG SPEED, VOLTS INPUT
9	VIOLET	CONTINUOUS / DISPENSE

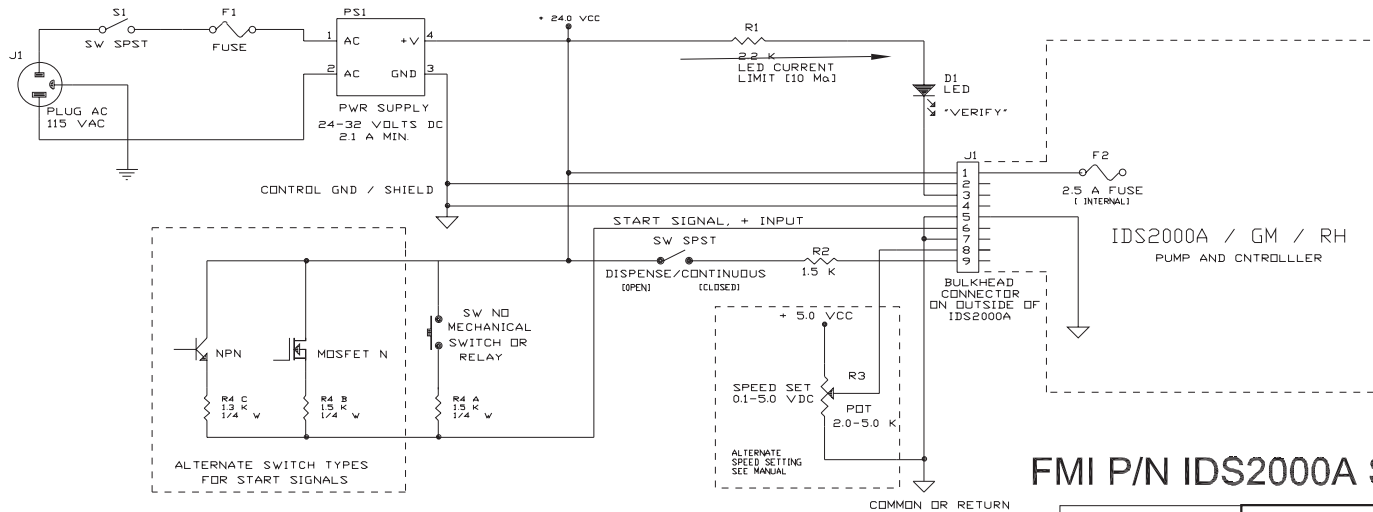

**FMI P/N IDS2000A SERIES**

NOTES:

- INPUT SIGNALS ARE TO BE 30 VOLTS MAX., AT 20 mA MAX, 5.0 mA MINIMUM.
- RESISTANCE VALUES SHOWN ARE TYPICAL FOR 24 VOLT SIGNALS. FOR OTHER VOLTAGES, SEE THE MANUAL.

NOTICE TO PERSONS RECEIVING THIS DRAWING  
 FLUID METERING INC. CLAIMS PROPRIETARY RIGHTS IN THE MATERIAL DISCLOSED HEREON. THIS DRAWING IS LOANED IN CONFIDENCE FOR INFORMATIONAL PURPOSES ONLY AND MAY NOT BE REPRODUCED, DISTRIBUTED, SOLD, RENTED, OR USED TO MANUFACTURE ANYTHING SHOWN HEREON WITHOUT DIRECT PRIOR WRITTEN PERMISSION FROM FLUID METERING, INC. TO THE USER. THIS DRAWING IS LOANED FOR MUTUAL ASSISTANCE AND REMAINS THE PROPERTY OF FLUID METERING, INC. IT IS SUBJECT TO RECALL AT ANY TIME.

TOLERANCES UNLESS OTHERWISE SPECIFIED	X = ±0.15 XX = ±0.10 XXX = ±0.05 ANG = ±1°
DO NOT SCALE	SURFACE FINISH 63

**Fluid Metering Inc.**  
 5 Aerial Way, Suite 500  
 Syosset, NY 11791

Chemical Metering Pumps

MATERIALS		DATE	
MATL	N/A	DATE	2/5/04
FINISH	N/A	DATE	2/19/04
DRAWN BY	W.A.	DATE	2/19/04
CHECKED BY	C.J.	DATE	2/19/04
APP'D BY	C.J.	DATE	2/19/04
ORIG DWG BY	A.N.S.	DATE	6/8/02
FILENAME	700021.DWG	SCALE	DWG NO.
USED ON	NONE		700021
		REV	D

TITLE  
**EXAMPLE  
 IDS 2000A  
 START SIGNALS**

5th 1 of 1